



www.hirschmann.com

**HIRSCHMANN**

# **PAT** **LOAD MOMENT INDICATOR**

## **DS 350GM**

for Grove Cranes



## **SERVICE MANUAL**

P/N 031-300-190-041 REV K 12/05/2005



## NOTICE

**The information in this document is subject to change without notice.**

**Hirschmann Electronics, Inc. makes no warranty of any kind with regard to this material, including, but not limited to the implied warranties of merchantability and fitness for a particular purpose.**

**Hirschmann shall not be liable for errors contained in this manual or for incidental or consequential damages in connection with the furnishing, performance, or use of this manual. This document contains proprietary information, which is protected by copyright. All rights are reserved.**

**No part of this document may be photocopied, reproduced, or translated into another language without the prior written consent of Hirschmann.**

**Hirschmann reserves proprietary rights to all drawings and to the data shown thereon. The drawings and data are confidential and are not to be used or reproduced without prior written consent from Hirschmann. The drawings are subject to technical modification without prior notice.**

## MANUAL REVISIONS

REV	DATE	NAME	DESCRIPTION
-	11/18/98	CSH	Preliminary troubleshooting manual created for customer review and feedback.
A	01/08/98	CSH	Add measuring points and jumper positions to drawings. Add Theory Section 13. Change Table of Contents
B	02/20/98	CSH	Add LED'S to DWG 7 and LED H12 TxD to pg. 17 Correct pg. 25 E91-E94 see to section 9
C	06/17/99	CSH	Correct reference notes pg. 5,15,16 Correct troubleshooting action pg. 19 Add rest boom, no pressure hydraulic lines procedure 4. Correct minor verbiage in Theory 1,3
D	10/15/99	CSH	Add slewing angle reading problem, Section11. Add slew potentiometer adjustment, Procedure 6. Move error codes to Section 2. Update/correct flow charts and drawings.
E	11/15/99	CSH	Correct Section numbers and reference numbers Change Theory Section Change to double sided pages
F	01/24/00	SB	Add Grove Part Numbers
G	04/25/01	SB	ECN 01-139
H	04/23/02	CH	ECN 02-141
J	11/07/02	CH	ECN 02-267
K	12/05/05	SB	ECN 05-216



---

**TABLE OF CONTENTS**

<b>1</b>	<b>General Information</b> .....	<b>1</b>
<b>2</b>	<b>Warnings</b> .....	<b>2</b>
<b>3</b>	<b>Flowcharts</b> .....	<b>3</b>
3.1	GENERAL FLOWCHART .....	3
3.2	ERROR CODE DISPLAY .....	4
3.3	LEVER LOCKOUT ACTIVATED .....	14
3.4	BROKEN LENGTH CABLE .....	15
3.5	NO DISPLAY .....	16
3.6	ANTI-TWO BLOCK PROBLEM .....	18
3.7	LENGTH READING PROBLEM .....	21
3.8	ANGLE READING PROBLEM .....	24
3.9	LOAD READING PROBLEM .....	26
3.10	BAD DATA TRANSFER BETWEEN CONSOLE & CENTRAL UNIT OR INTERFERENCE PROBLEM .....	28
3.11	SLEWING ANGLE READING PROBLEM .....	30
<b>4</b>	<b>Drawings</b> .....	<b>32</b>
4.1	DRAWING 1. ELECTRICAL WIRING FOR CENTRAL UNIT TO PRESSURE TRANSDUCERS AND CRANE .....	32
4.2	DRAWING 2. ELECTRICAL WIRING FOR CENTRAL UNIT TO CONSOLE .....	33
4.3	DRAWING 3. ELECTRICAL WIRING FOR CENTRAL UNIT TO CABLE REEL/ANTI-TWO BLOCK .....	34
4.4	DRAWING 4. CENTRAL UNIT - PARTS LIST .....	35
4.5	DRAWING 5A. CONSOLE DS350/1319 - PARTS LIST .....	37
4.6	DRAWING 5B. CONSOLE DS350/1318 - PARTS LIST .....	39
4.7	DRAWING 6. CABLE REEL - PARTS LIST .....	41
4.8	DRAWING 7. CENTRAL UNIT MAIN BOARD LAYOUT .....	43
4.9	DRAWING 8. CONSOLE CONNECTION BOARD .....	44
4.10	DRAWING 9. CENTRAL UNIT ANALOG INPUT MODULE .....	45
<b>5</b>	<b>Procedures</b> .....	<b>46</b>
5.1	PROCEDURE 1. STRAIN RELIEF INSTALLATION .....	46
5.2	PROCEDURE 2. EPROM LOCATION AND INSTALLATION .....	47
5.3	PROCEDURE 3. MAIN BOARD REPLACEMENT .....	48
5.4	PROCEDURE 4. PRESSURE TRANSDUCER ZERO ADJUSTMENT .....	49
5.4.1	USING GRAPHIC CONSOLE FOR ZERO-SETTING OF PRESSURE TRANSDUCER & FORCE INPUTS .....	49
5.5	PROCEDURE 5. LENGTH AND ANGLE SENSOR ADJUSTMENT .....	50
5.6	PROCEDURE 6. SLEW POT POTENTIOMETER ZERO ADJUSTMENT .....	51
5.6.1	USING GRAPHIC CONSOLE FOR ZERO-SETTING OF SLEW POT POTENTIOMETER .....	51

<b>6</b>	<b>Theory .....</b>	<b>52</b>
6.1	THEORY 1. OPERATION OF BOOM LENGTH SENSOR .....	52
	Measuring current: .....	52
	Measuring voltage: .....	52
6.2	THEORY 2. OPERATION OF PISTON SIDE LOAD SENSOR .....	53
6.3	THEORY 3. OPERATION OF ROD SIDE LOAD SENSOR.....	54
6.4	THEORY 4. OPERATION OF ANGLE SENSOR .....	55
6.5	THEORY 5. OPERATION OF SLEW POTENTIOMETER SENSOR.....	56
6.6	THEORY 6. OPERATION AXLE OSCILLATION OUTPUT .....	57

# 1 GENERAL INFORMATION

This troubleshooting manual is designed to assist a service or maintenance person in identifying system problem areas or malfunctions. A digital voltmeter with the capability to also measure current will be required. Regular maintenance and service tools will also be required. NOTE: Knowledge of how to use a voltmeter to measure both voltage and current is assumed.

## REFERENCE:

For system operation, refer to the operator's manual for the console. This may differ from crane manufacturer and model.

Section 3.1 is a general flow chart that directs you to detailed flow charts and sections.

Section 3.2 provides a list of error codes, error, cause, and possible action for the error.

Sections 3.3 – 3.11 provide detailed flow charts to define and correct the root cause.

Section 4 provides drawings that will be referenced for troubleshooting.

Section 5 provides procedures that will be referenced for troubleshooting.

Section 6 provides drawings for the theory of operation of all the different sensing devices used in the DS350G Modular System. Use these reference drawings to better understand the operation of the system.

## 2 WARNINGS

The LMI is an operational aid that warns a crane operator of approaching overload conditions and overhoist conditions that could cause damage to equipment and personnel. Therefore, the device is not, and shall not be, a substitute for good operator judgment, experience and use of accepted safe crane operating procedures.

The responsibility for the safe crane operation shall remain with the crane operator who shall ensure that all warnings and instructions supplied are fully understood and observed.

Prior to operating the crane, the operator must carefully and thoroughly read and understand the information in the crane's operating manuals to ensure that the operator knows the operation and limitations of indicator and crane.

### **PAT Load Moment Indicator (LMI) DS 350 Modular**

The PAT Load Moment Indicator (LMI) DS 350 Modular has been designed to provide the crane operator with the essential information required to operate the machine within the designed parameters. Using different sensing devices, the DS 350 Modular LMI monitors various crane functions and provides the operator with a continuous display of the crane's capacity. The display continually changes as the crane moves through the motions needed to make a lift.

If non-permitted conditions are approached, the DS 350 LMI will warn the operator by sounding an audible alarm and lighting a warning light. In addition the LMI system has the capability to provide a signal to the solenoids and thereby locking out those functions that may aggravate the crane's condition.



### 3 FLOWCHARTS

#### 3.1 GENERAL FLOWCHART

This section explains how to handle a problem that may arise with the PAT DS 350 Modular LMI. The procedures are given in flowchart format for the following sections. Start with the general flowchart below that will guide you to one of the detailed flowcharts shown in Sections 2 through 11. The drawings and procedures that are referenced in these sections can be found in Sections 12 and 13.

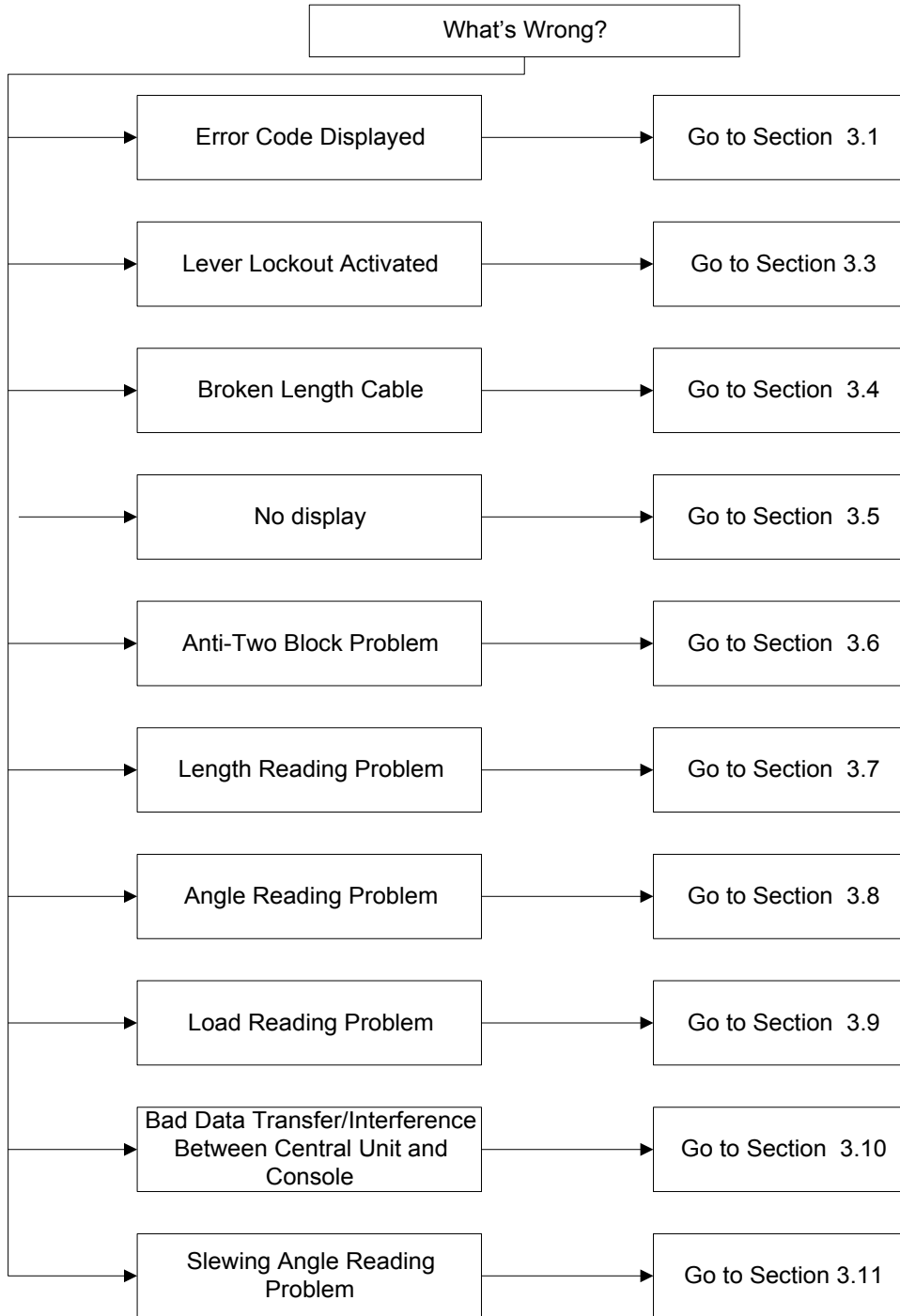

### 3.2 ERROR CODE DISPLAY

PROBLEM: Error code displayed. Lever lockout activated. Warning lights on.

ERROR CODE	ERROR	CAUSE	ACTION
E01	Minimum radius or maximum angle range exceeded	Fallen below the minimum radius or above the angle given in the load chart due to raising the boom too far.	Lower boom back to a radius or angle given in the load chart.
E02	Maximum radius or minimum angle range exceeded	The maximum radius or minimum angle given in the load chart was exceeded due to lowering the boom too far.	Raise boom back to a radius or angle given in the load chart.
E03	Prohibited slewing range (no load area)	Slewing range prohibited with load.	Slew back into admissible range.
E04	Operating mode not available or non permitted slewing zone.	A non existing operating mode has been selected. The boom is in a non permitted slewing zone.	Set operating mode switch correctly to the code assigned to the operating mode of the crane. Slew the boom to a permitted area.
E05	Length range not permitted	Boom has been extended too far or not far enough. Length sensor adjustment changed; i.e. length sensor cable slid off the cable drum.	Refer to Section 3.7. Retract or extend boom to correct length given in the load chart.
E06	Fallen below angle range with luffing jib operation.	Fallen below the minimum jib angle specified in the respective load chart due to luffing out the jib too far.	Luff in the jib to a radius or angle specified in the load chart.
E07	No acknowledgment signal from overload relay (K1).	Overload relay is stuck, defective or not being selected.	Replace main board in central unit. Refer to Drawing 4 and Procedure 3 in Section 5.3
E08	No acknowledgment signal from Anti-Two-Block switch relay (K2).	Anti-Two-Block switch relay is defective or not being selected.	Replace main board in central unit. Refer to Drawing 4 and Procedure 3 in Section 5.3.
E10	Error in length measurement	With the boom fully retracted, the length differs by more than 2%.	Refer to Section 3.7.

<b>ERROR CODE</b>	<b>ERROR</b>	<b>CAUSE</b>	<b>ACTION</b>
E11	Fallen below limit for the measuring channel "length".	a.) Cable between length sensor and central unit defective, not connected or water in the connectors. b.) Length sensor Potentiometer defective. c.) Electronic board in the measuring channel defective.	Refer to Section 3.7 a.) Check cable and connector b.) Check and reset length sensor Potentiometer. Refer to Procedure 5. c.) Check signal on main board and analog input module.
E12	Fallen below lower limit value for the measuring channel "pressure transducer piston side".	a.) Cable leading from the central unit to the pressure transducer defective, loose or water in the connector. b.) Pressure transducer on piston side defective. c.) Electronic component in the measuring channel defective.	Refer to Section 3.9 a.) Check cable and connector b.) Check pressure transducer and reset pressure channel. c.) Check signal on main board and analog input module.
E13	Fallen below lower limit value for the measuring channel "pressure transducer rod side".	a.) Cable leading from the central unit to the pressure transducer defective, loose or water in the connector. b.) Pressure transducer on rod side defective. c.) Electronic component in the measuring channel defective.	Refer to Section 3.9 a.) Check cable and connector b.) Check pressure transducer and reset pressure channel. c.) Check signal on main board and analog input module.
E14	Fallen below lower limit value for the measuring channel "force".	a.) Cable leading from the central unit to the pressure transducer defective, loose or water in the connector. b.) Force transducer defective. c.) Electronic component in the measuring channel defective.	a.) Check cable and connectors as well and replace, if necessary. b.) Check force transducer. c.) Check signal on main board and analog input module.
E 15	Fallen below lower limit value for the measuring channel "angle main boom".	a.) Cable from central unit to the length/angle sensor defective or loose. b.) Angle sensor defective. c.) Electronic component in the measuring channel defective.	Refer to Section 3.8 a.) Check cable. b.) Check angle sensor and reset adjustment. Refer to Procedure 5 c.) Check signal on main board and analog input module.

<b>ERROR CODE</b>	<b>ERROR</b>	<b>CAUSE</b>	<b>ACTION</b>
E16	Fallen below lower limit value for measuring channel "Luffing Jib Angle".	a.) Cable from central unit to angle sensor defective or disconnected or water inside the plug. b.) Angle sensor defective. c.) Electronic component in the measuring channel defective.	a.) Check cable. b.) Check angle sensor and reset adjustment. c.) Check signal on main board and analog input module.
E17	Fallen below lower limit value "length telescope I (+II)"	a.) Cable between the central unit to the length sensor defective or loose. Water inside the length sensor plug. b.) Length potentiometer defective c.) Electronic component in the measuring channel defective	a.) Check cable and connectors.  b.) Replace length sensor. c.) Replace LMI main board or processor board.
E18	outrigger overloaded	Front outrigger overloaded	Check outrigger sensor
E19	Error in the reference voltage.	Electronic component on the main board defective.	Replace main board. Refer to Drawing 4 and Procedure 3.
E1A	Below limiting value for slewing angle 1.	a.) Cable from central unit to the slewing angle sensor defective or loose.	Refer to Section 3.11. a.) Check cable.
E1B	Below limiting value for slewing angle 2.	b.) Slewing angle potentiometer defective. c.) Electronic component in the measuring channel defective on main board.	b.) Check and reset slewing angle potentiometer. Refer to Procedure 6. c.) Check signal on main board and analog input module.
E21	Upper limiting value for the measuring channel "length" exceeded.	a.) Cable from central unit to the length/angle sensor defective or loose. b.) Length potentiometer defective. c.) Electronic component in the measuring channel defective on main board.	Refer to Section 3.7 a.) Check cable and connector b.) Check and reset length sensor Potentiometer. Refer to Procedure 5. c.) Check signal on main board and analog input module.

ERROR CODE	ERROR	CAUSE	ACTION
E22	Upper limiting value for the measuring channel "pressure piston side" exceeded.	a.) Cable from central unit to the pressure transducer defective, loose or water in the plug. b.) Pressure transducer on piston side defective. c.) Electronic component in the measuring channel defective on main board.	Refer to Section 3.9 a.) Check cable and connector b.) Check pressure transducer and reset pressure channel. c.) Check signal on main board and analog input module.
E23	Upper limit value for the measuring channel "pressure transducer rod side" exceeded.	a.) Cable lead in from the central unit to press trans defective, not connected or water in the connectors. b.) Pressure transducer on rod side defective. c.) Electronic component in the measuring channel defective.	Refer to Section 3.9 a.) Check cable and connector b.) Check pressure transducer and reset pressure channel. c.) Check signal on main board and analog input module.
E24	Upper limit value for the measuring channel "force" exceeded.	a.) Cable leading from the central unit to the force transducer defective, not connected or water in the connectors. b.) Force transducer defective. c.) Electric component in the measuring channel defective.	a.) Check cable and connectors as well and replace, if necessary. b.) Check force transducer. c.) Check signal on main board and analog input module.
E25	Upper limit value for the measuring channel "angle main boom" exceeded.	a.) Cable leading from the central unit to the length/angle sensor defective, loose or water in the connectors. b.) Angle sensor defective c.) Electronic component in the measuring channel defective.	Refer to Section 3.8 a.) Check cable. b.) Check angle sensor and reset adjustment. Refer to Procedure 5 c.) Check signal on main board and analog input module.
E26	Upper limit value for the measuring channel "Luffing Jib Angle" exceeded.	a.) Cable leading from the central unit to the jib angle sensor defective, loose or water in the connectors. b.) Jib angle sensor defective. c.) Electronic component in the measuring channel defective.	a.) Check cable. b.) Check angle sensor and reset adjustment. c.) Check signal on main board and analog input module.

ERROR CODE	ERROR	CAUSE	ACTION
E27	Upper limit value in measuring channel "length telescope I (+II) has been exceeded.	a.) Cable between the central unit to the length sensor defective or loose. Water inside the length sensor plug. b.) Length potentiometer defective c.) Electronic component in the measuring channel defective	a.) Check cable and connectors.  b.) Replace length sensor.  c.) Replace LMI main board or processor board.
E29	Reference voltage defective.	a.) The total of the supply and the reference voltages on MP10 is more than 3.3V b.) A/D converter defective.	a.) Check supply voltages. b.) Replace main board or analog input module. Refer to Drawing 4 and Procedure 3 Steps 1,2,4, 11,12..
E2A	Above limiting value for slewing angle 1.	a.) Cable from central unit to the slewing angle sensor defective or loose.	Refer to Section 3.11. a.) Check cable 6.
E2B	Above limiting value for slewing angle 2.	b.) Slewing angle potentiometer defective. c.) Electronic component in the measuring channel defective on main board.	b.) Check and reset slewing angle potentiometer. Refer to Procedure 6. c.) Check signal on main board and analog input module.
E31	Error in the system program.	a.) EPROM with system program defective. b.) Electronic component on the main board defective.	a.) Replace system program EPROM b.) Check signal on main board and analog input module.
E37	Error in the program run	a.) EPROM with system program defective. b.) Electronic component on the main board defective.	a.) Replace system program EPROM. b.) Check signal on main board and analog input module.
E38	System program and Data EPROM do not match.	The system program in the LMI does not correspond to the programming in the data EPROM	Replace system program EPROM or Data EPROM. Refer to Procedure 2
E39	System program and TLK EPROM do not match.	The system program in the LMI does not correspond to the programming in the data EPROM	Replace system program EPROM or TLK EPROM. Refer to Procedure 2
E41	Error in the external RAM.	Defective electronic component.	Replace main board or analog input module. Refer to Drawing 4 and Procedure 3, Steps 1,2,4, 11, and 12.

<b>ERROR CODE</b>	<b>ERROR</b>	<b>CAUSE</b>	<b>ACTION</b>
E42	Error in the external write/read memory (RAM). Part 1	Internal defect in digital part of CPU.	Exchange write/read memory (CMOS-RAM). Replace CPU module. Refer to Drawing 4 and Procedure 3, Steps 1-3, 13,14.
E43	Error in the external write/read memory (RAM). Part 2.	Internal defect in digital part of CPU.	Exchange write/read memory (CMOS-RAM). Replace CPU module. Refer to Drawing 4 and Procedure 3, Steps 1-3, 13,14.
E45	Redundancy error in A/D conversion.	Defective electronic component.	Replace analog input module. Refer to Drawing 4 and Procedure 3, Steps 1,2,4, 11,12.
E46	Error in A/D conversion.	Defective electronic component.	Replace analog input module. Refer to Drawing 4 and Procedure 3 Steps 1,2,4, 11,12.
E47	Malfunction in the monitored write/read memory.	Internal defect in digital part of CPU	Replace CPU module. Refer to Drawing 4 and Procedure 3 Steps 1-3, 13,14
E48	Cyclic RAM test: Error in the internal write/read memory.	Internal defect in digital part of CPU	Replace CPU module. Refer to Drawing 4 and Procedure 3 Steps 1-3, 13,14
E51	Error in data EPROM.	EPROM Module not bridged correctly Data EPROM on the main board defective.	Replace Data EPROM. Make sure BR3 on the main board is installed. Refer to Procedure 2.
E52	Error in load chart EPROM.	EPROM Module not bridged correctly Data EPROM on the main board defective.	Replace EPROM Module and reset pressure channels. Refer to Drawing 4 and Procedure 4.
E56	Error in crane data EEPROM.	Memory module wrongly bridged.  Crane data EEPROM defective	Bridge memory module acc. To memory type Replace crane data EEPROM Replace EPROM Module and reset pressure channels. Refer to Drawing 4 and Procedure 4.

<b>ERROR CODE</b>	<b>ERROR</b>	<b>CAUSE</b>	<b>ACTION</b>
E57	Error in serial crane data EEPROM.	Serial crane data EEPROM does not contain valid data.  Memory module defective	Write data on the serial crane data EEPROM (by means of test program or on-line function), then restart the LMI Replace EPROM Module and reset pressure channels. Refer to Drawing 4 and Procedure 4.
E58	Error in the serial analog data EEPROM.	No valid data in the serial analog data EEPROM.  LMI main board defective.	Write data on the serial analog data EEPROM by means of the test program, then, restart the LMI Replace LMI main board.
E60	The number of the selected EPROM base and the programmed value are not identical	Load chart EPROM defective  Base number not programmed  Load chart EPROM wrongly programmed	Replace load chart EPROM  Program the correct base number (1 for base 1, 2 for base 2) Check base programming in the load chart EPROM.
E61	Error in the boom control extension.	Cable between the central unit and the boom control extension defective. Profibus adapter in the central unit defective Profibus adapter in the Boom control extension defective Boom control extension defective	Check the cable to the boom control extension  Replace the profibus adapter  Replace the profibus adapter  Replace the boom control extension
E62	Error digital inputs 1 - 8 in the boom control extension.	Module for digital inputs in the Boom control extension defective Boom control extension defective	Replace the module for the digital inputs  Replace the boom control extension
E63	Error digital inputs 9 - 16 in the boom control extension.	Module for digital inputs in the Boom control extension defective Boom control extension defective	Replace the module for the digital inputs  Replace the boom control extension



ERROR CODE	ERROR	CAUSE	ACTION
E64	Error analog output 1 in the boom control extension.	Module for analog output 1 in the Boom control extension defective Boom control extension defective	Replace the module for the analog output 1 Replace the boom control extension
E65	Error analog output 2 in the boom control extension.	Module for analog output 2 in the Boom control extension defective Boom control extension defective	Replace the module for the analog output 2 Replace the boom control extension
E66	Error analog outputs in the boom control extension.	Module for analog outputs in the Boom control extension defective Boom control extension defective	Replace the module for the analog outputs Replace the boom control extension
E69	Error in the load chart EPROM The number of the selected EPROM base and the programmed value are not identical	Memory module wrongly bridged Load chart EPROM defective	Bridge memory module acc. to memory type Replace load chart EPROM
E70	Error in digital output module.	Central unit unable to correspond with digital output module.	Check supply voltage. Replace digital output module, refer to section 14,theory 6.
E71	Incorrect acknowledgment of the 1. Relay on the main board.	a.) Anti Two-block relay is stuck or defective. b.) Anti Two-Block relay is not being selected due to a break on the main board.	Replace main board. Refer to Drawing 4 and Procedure 3.
E72 – E77	Analogous to E71 for the relays 2...7.	Analogous to E71 for the relays 2...7.	Analogous to E71 for the relays 2..7.
E80	Error in the slewing angle measurement	The difference between the average of the slewing angle and one of the wipers of the slewing potentiometer is out of the tolerance	Check the slewing potentiometer adjustment Replace the slewing potentiometer
E84	Wrong rigging condition.	The selected rigging condition is not contained in the data EPROM.	Select another rigging condition Check the programming in the data EPROM.
E85	Error in the radius determination	The computed radius is too small (negative deflection)	Check the programming in the data EPROM.
E86	Faulty percentage for at least one telescope.	a) Telescope has a percentage <-25 or > 106%. b) Length measurement Tele I+II is defective. c) Measurement of overall length is defective.	a) Read out the percentages on the console. If a telescope has to be extended too far: retract tele and bolt. b) Check length measurement Tele I (see E17) c) Check length measurement (see E11)

ERROR CODE	ERROR	CAUSE	ACTION
E89	Change of the operating code during lifting a load.	The operating mode switch in the console was used during lifting a load.	Lower the load and set the operating mode switch correctly to the code assigned to the actual operating mode of the crane.
E91	No data transmission from console to central unit. (Refer to Section 9)	a.) 24V supply of console interrupted. b.) Interruption or accidental ground in the line from console electronics to central unit. c.) Transmitter/receiver module defective.	a.) Check 24V at terminal X1 of console electronics. b.) Check the connection between console electronics and central unit. c.) If accidental ground occurs, the transmitter module in the console electronics can be damaged. Replace the console electronics or main board respectively.
E92	Error in the data transmission from console to central unit. (Refer to also Section 3.10)	a.) Temporary interruption of the data line from console electronics to central unit. b.) Transmitter/receiver module defective.	a.) Check the connection between console electronics and central unit.
E93	Error in the data transmission from central unit to console. (Refer to also Section 3.10)	a.) Temporary interruption of the data line from console electronics to central unit. b.) Transmitter/receiver module defective.	Refer to Section 3.10. a.) Check the connection between console electronics and central unit. b.) Replace console electronics or main board respectively.
E94	No data transmission for central unit to console. (Refer to also Section 3.10)	a.) Interruption or accidental ground in the line from console electronics to central unit.  b.) Transmitter/receiver module defective. c.) Data-EPROM defective. d.) CPU defective.  e.) Electromagnetic interference (when switching contractors or valves)	Refer to Section 3.10. a.) Check the connection between console electronics and central unit. If you find an accidental ground, the transmitter module in the console electronics can be damaged. Replace the console electronics. b.) Replace console electronics or main board respectively. c.) Check data EPROM. d.) Replace CPU module. Refer to Drawing 4 and Procedure 3 Steps 1-3, 13,14. e.) Eliminate interference source by inverse diodes or varistors.

ERROR CODE	ERROR	CAUSE	ACTION
E95	Error in the crane data EPROM	a.) Data EPROM defective b.) Position of jumper for the selection of the type of EPROM is wrong c.) Electronics component on the main board defective.	a.) Replace data EPROM b.) Check the jumper position c.) Replace CPU module. Refer to Drawing 4 and Procedure 3 Steps 1-3, 13,14
E96	Error in the internal RAM of the CPU of the console	CPU or main board of the console defective	Replace CPU module. Refer to Drawing 4 and Procedure 3 Steps 1-3, 13,14
E97	Error in the external RAM of the CPU of the console	a.) External RAM of the console defective b.) Electronic component on the main board defective.	a.) Replace console main board b.) Replace console main board Refer to Drawing 5.
E98	Wrong jumper position in the console	a.) The jumper position BR 9/BR 10 in the console does not correspond to the actual type of central unit. b.) Electronic component on the main board defective.	a.) Check the jumper position b.) Replace console main board Refer to Drawing 5.
EAB	Short circuit in the A2B switch circuit	Short circuit in the A2B switch Short circuit in the cable to the A2B switch  Electronic component on the analog input module defective.	Refer to Section 3.6. Replace A2B switch  Replace cable to the A2B switch  Check analog input module. Replace if necessary, Refer to Drawing 4 and Procedure 3 Steps 1,2,4, 11,12.
*EB0	Free fall switch on	* Free fall monitoring	DGA 9.4=0, DGA 9.5=0
*EB1	Free fall solenoid on	* Free fall monitoring	DGA 9.4=0, DGA 9.5=0
*EB2	Free fall switch and solenoid on	* Free fall monitoring	DGA 9.4=0, DGA 9.5=0
EC0	Prohibited area	Boom is about to collide with the engine hood, switch off	Check values in the data prom DGA 11.5.
EC1	Approaching prohibited area	Boom is about to collide with the engine hood, prewarning	Check values in the data prom DGA 11.5.

\* Free fall monitoring (only used with data logger DL352)

**Note:**

If an error message is displayed which is not contained in above list, please contact the Hirschmann service department.

### 3.3 LEVER LOCKOUT ACTIVATED

PROBLEM: The lever lockout system of the crane is activated. Crane movements “hoist up”, “telescope out”, and “boom down” are stopped. Crane is not in overload or two-block condition.

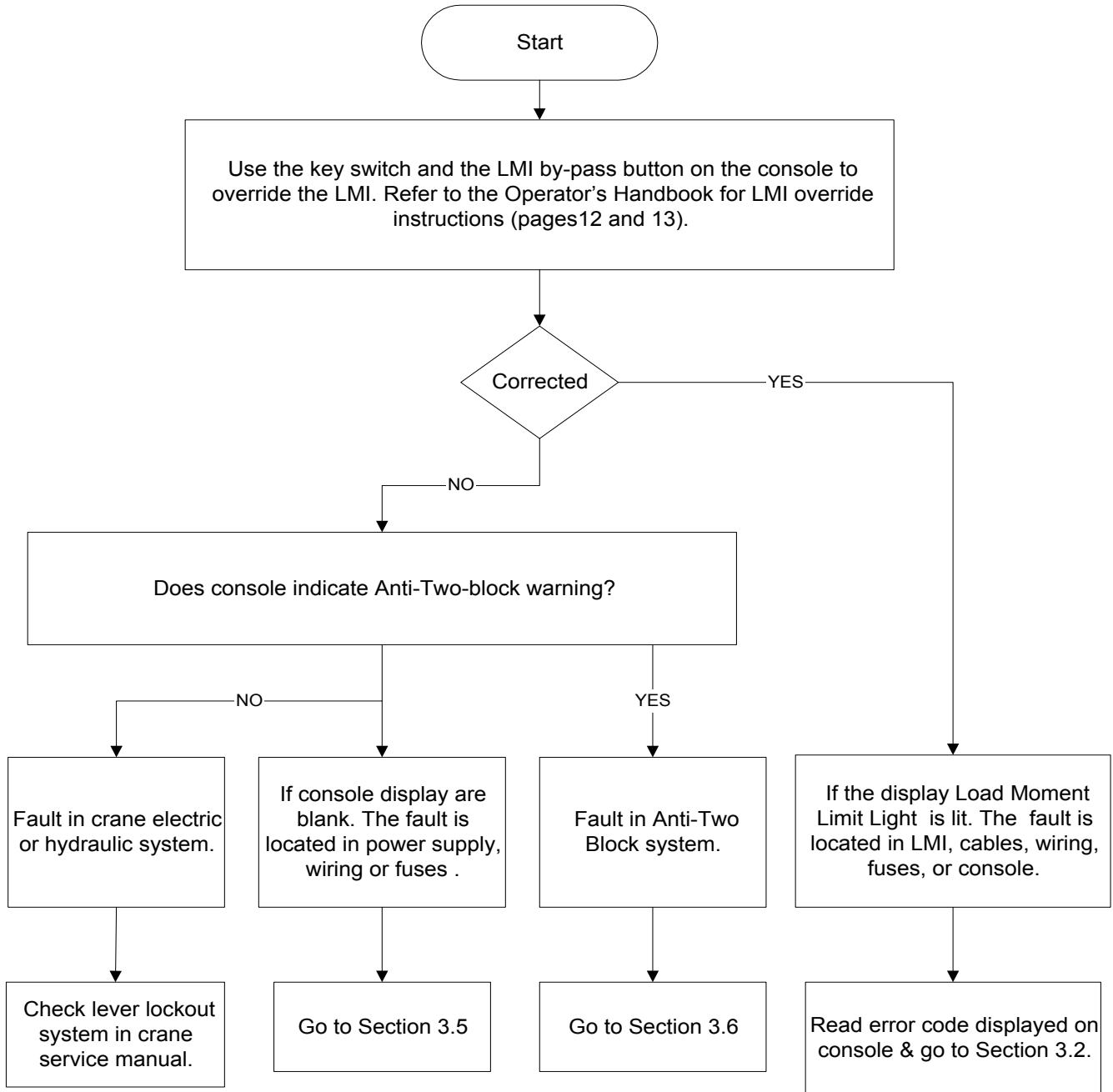

### 3.4 BROKEN LENGTH CABLE

PROBLEM: Damaged or broken length cable.

Replace length cable using the following procedure:

Refer to Section 4 for the following drawings:

Drawing 3 - Electrical Wiring Central Unit to Cable Reel

Drawing 6 - Cable Reel - Parts List

1. Cut old cable at cable drum.
2. Disconnect damaged length cable from junction box at the boom nose. Refer to Drawing 3.
3. Open cable reel cover and disconnect wiring from terminal block. Pull 7 conductor cable out of strain relief. Note: Mark wires to make re-connection simpler.
4. Remove cable reel from mounting brackets.
5. Remove damaged length cable, which is mounted to the slip rings in the cable reel, from slip ring terminal. Refer to Drawings 3.
6. On the back side of the cable reel, open the strain relief attached to the axle in the center of the drum. Pull existing length cable out of the cable reel.
7. Pull new length cable through the hole, pipe and strain relief and push it through the axle of the reeling drum. Tighten new strain relief to ensure sealing.
8. Reconnect the length cable to the slip ring. Refer to Drawing 3.
9. Remount cable reel to the boom.
10. Turn reeling drum clockwise to spool the new cable neatly onto the drum.
11. Set pre-load on cable reel by turning the drum counter-clockwise 5 to 8 turns.
12. Run the new length cable through the cable guides and wrap the length cable around the boom tip anchor pin (4 or 5 wraps) and secure with tie wraps. Leave enough length cable to connect into the boom tip junction box.
13. Connect the length cable into the boom tip junction box. Refer to Drawing 3.
14. Reset length potentiometer in length angle transducer (screw is located in center of white gear); with boom fully retracted, turn potentiometer carefully counter-clockwise until it stops. Recheck length and angle display. Refer to Procedure 5 in Section 5.5.

### 3.5 NO DISPLAY

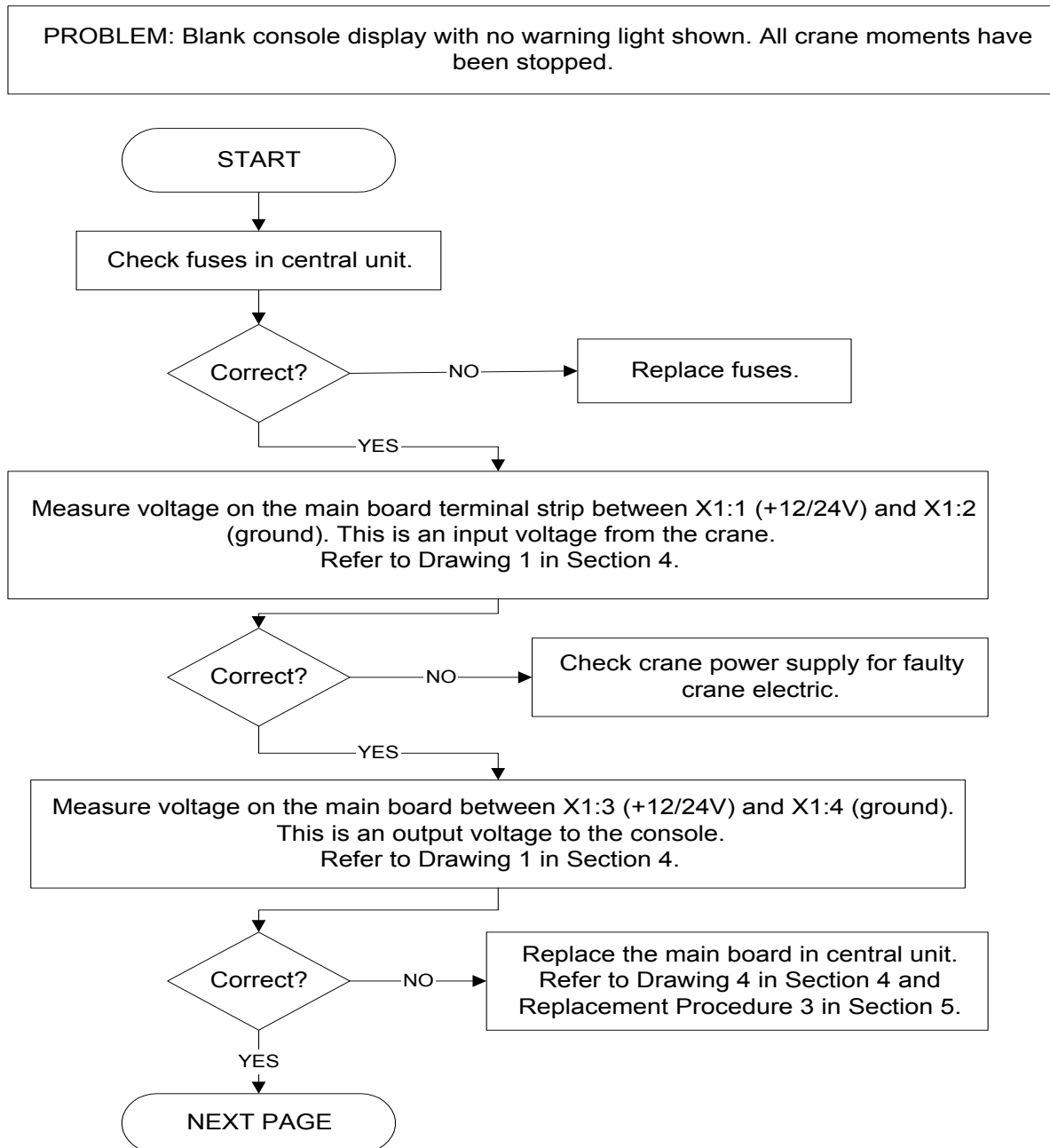

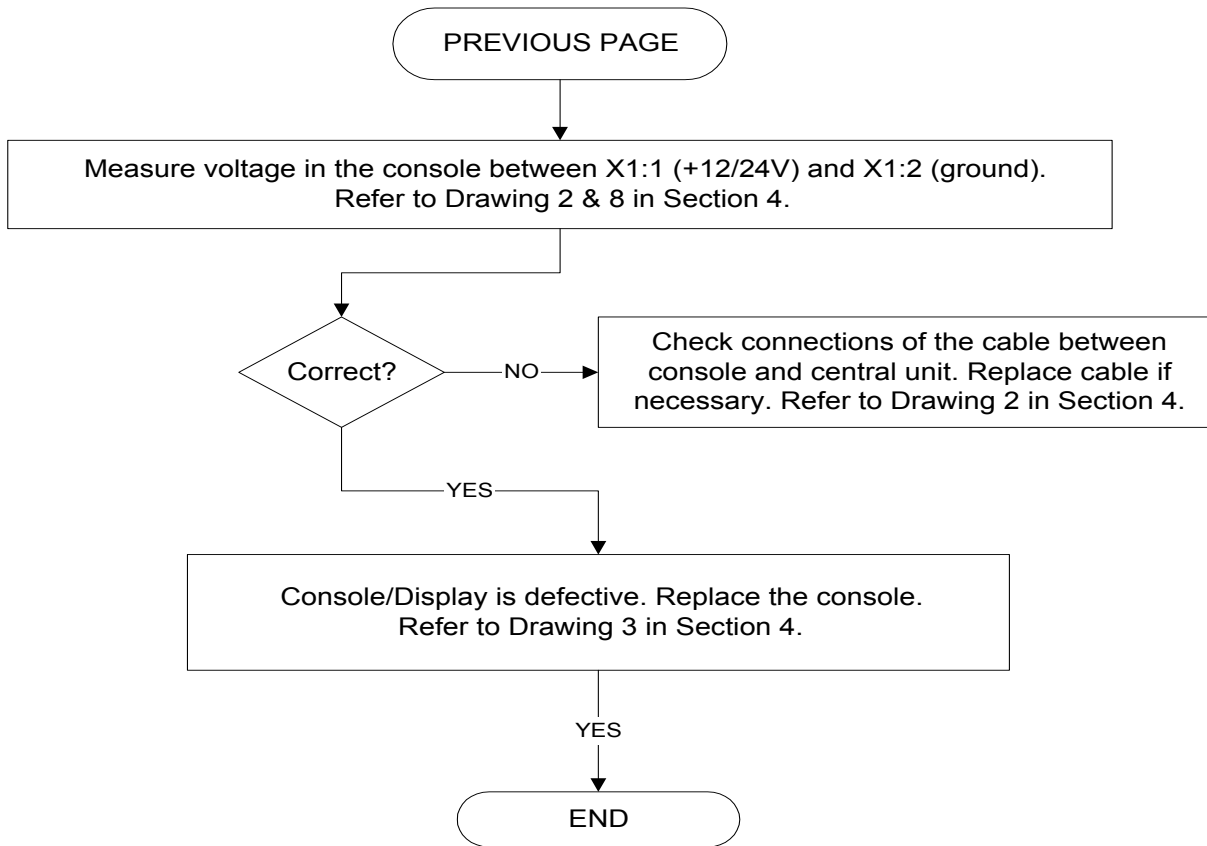

### 3.6 ANTI-TWO BLOCK PROBLEM

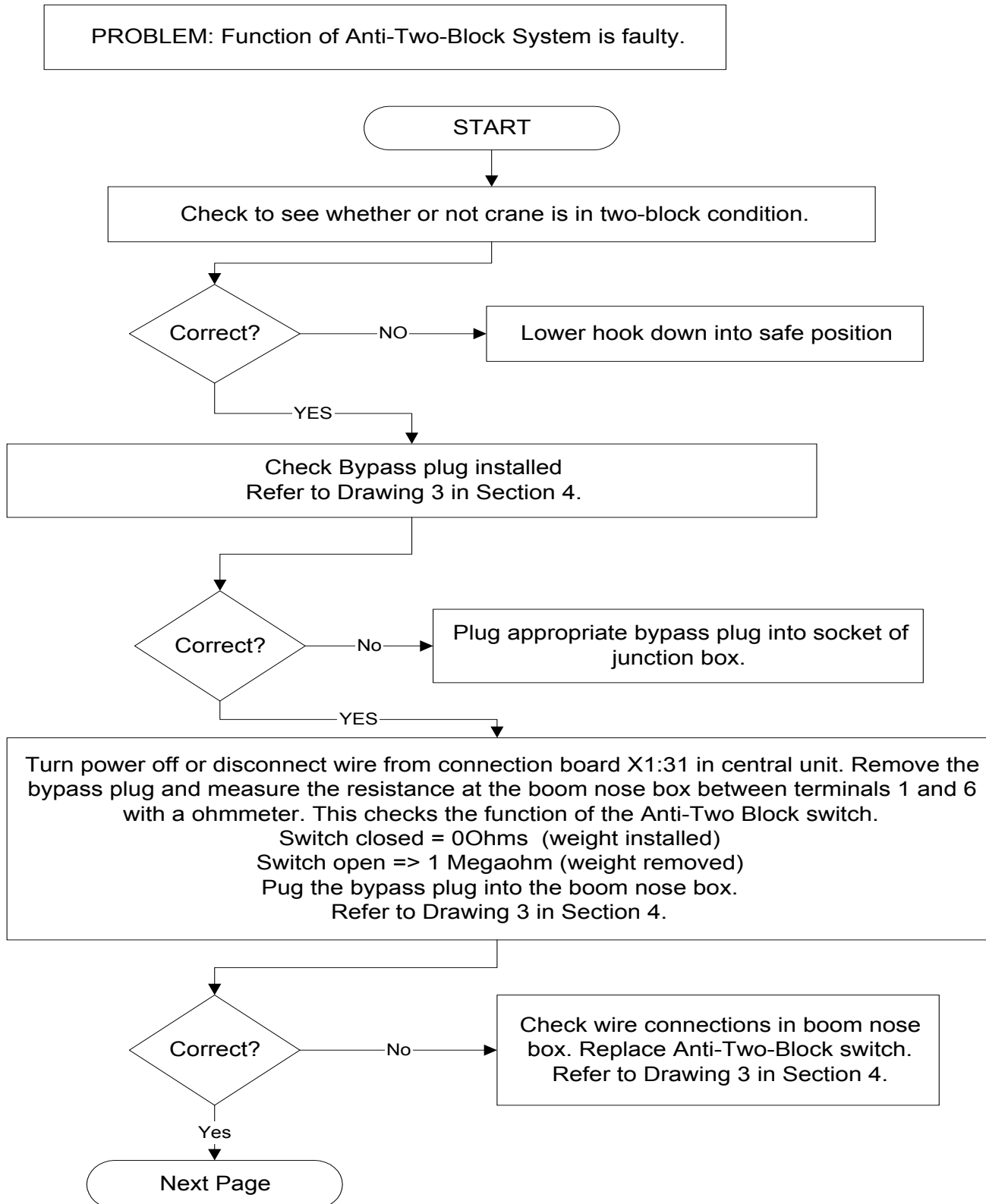



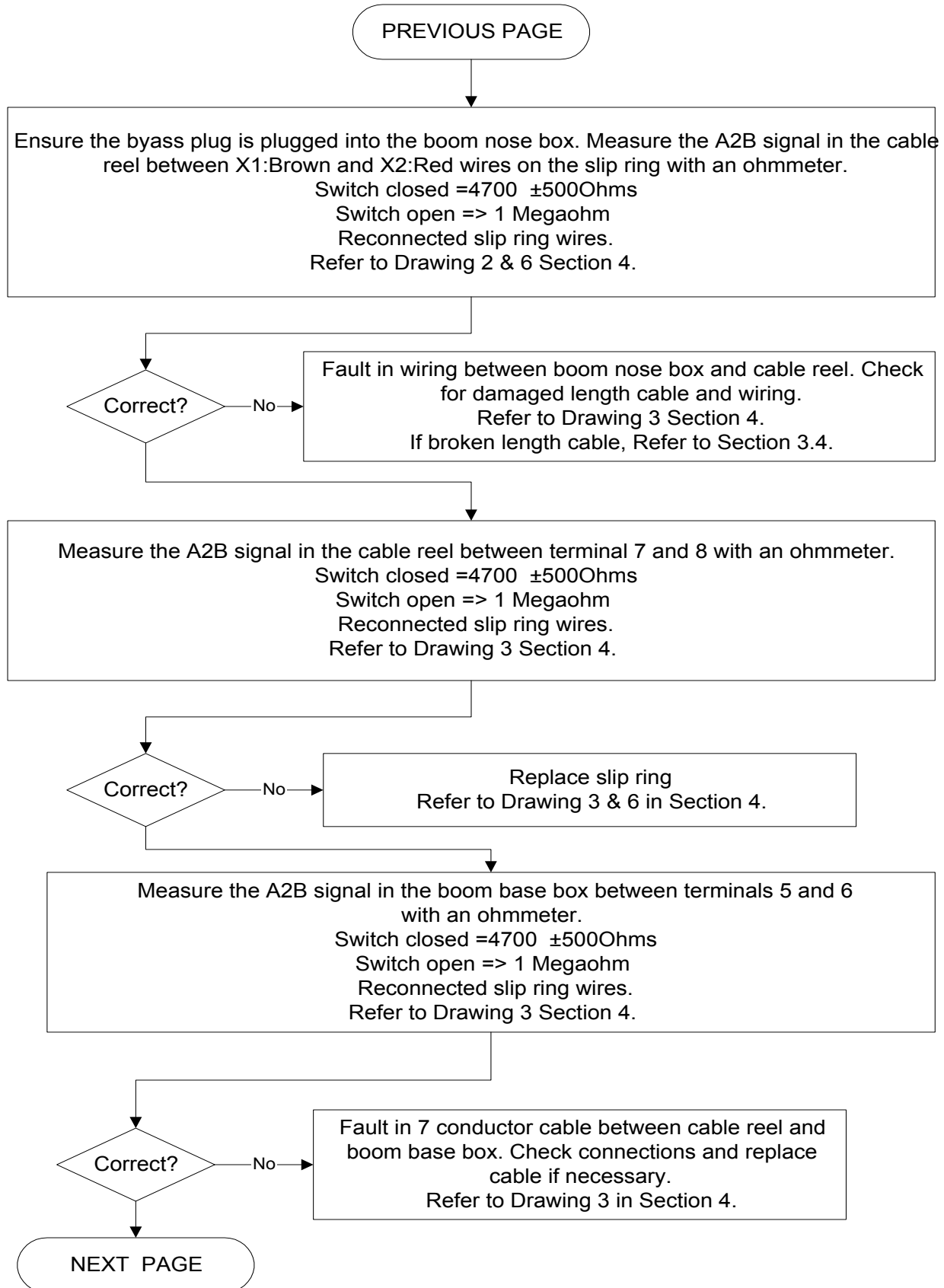

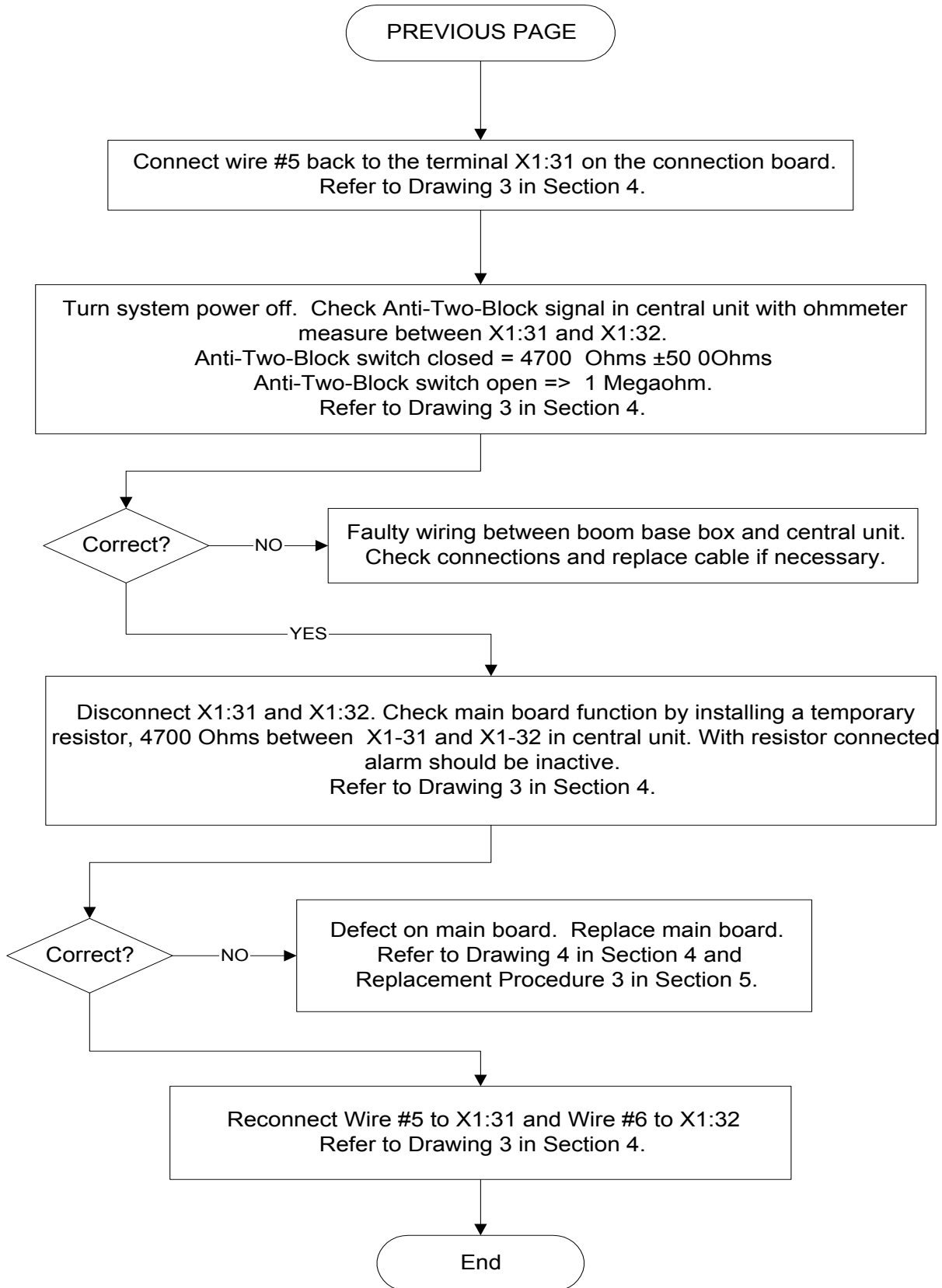

### 3.7 LENGTH READING PROBLEM

**PROBLEM:** Length displayed incorrect. Crane is not in "out of load chart" condition.

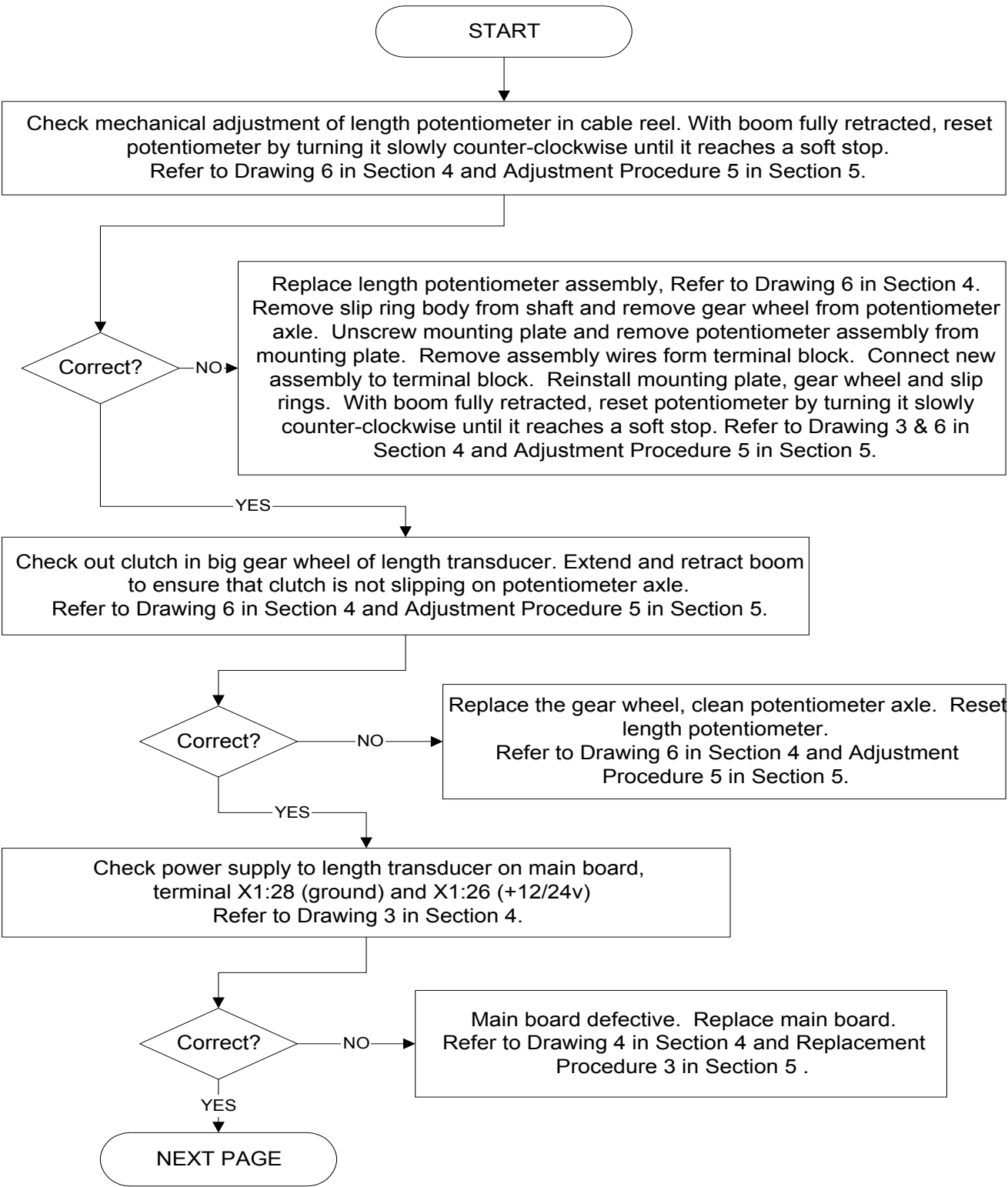

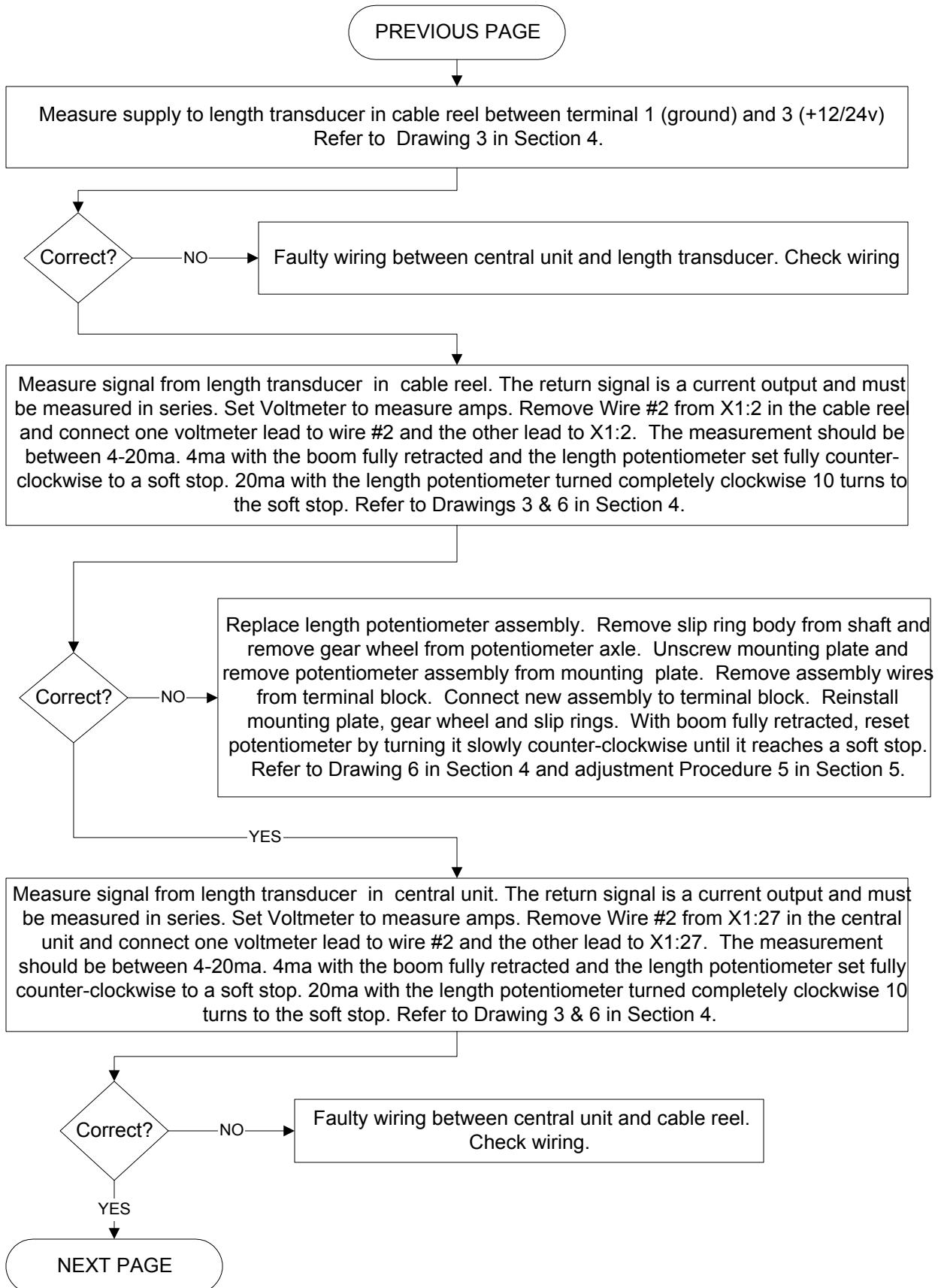

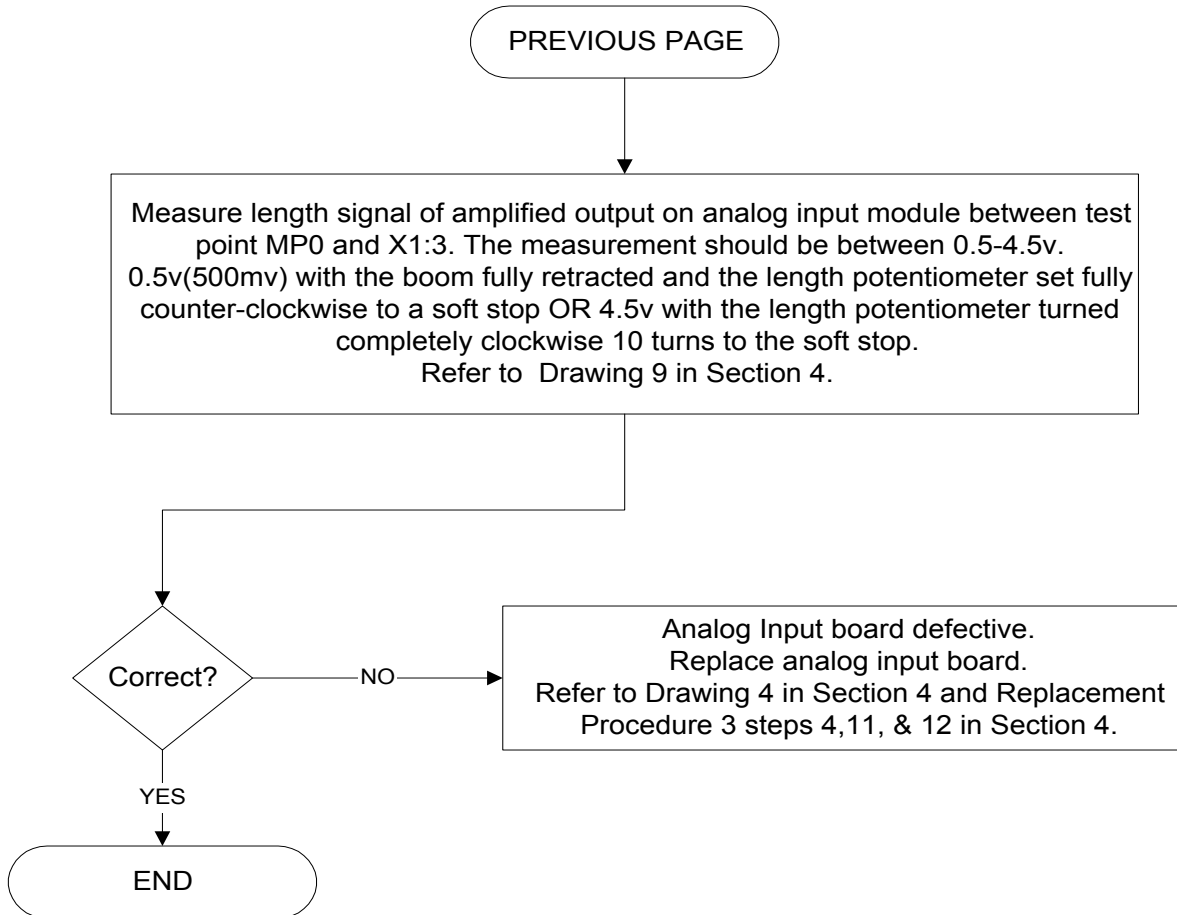

### 3.8 ANGLE READING PROBLEM

PROBLEM: Angle displayed incorrect. Crane is not in "out of load chart" condition.

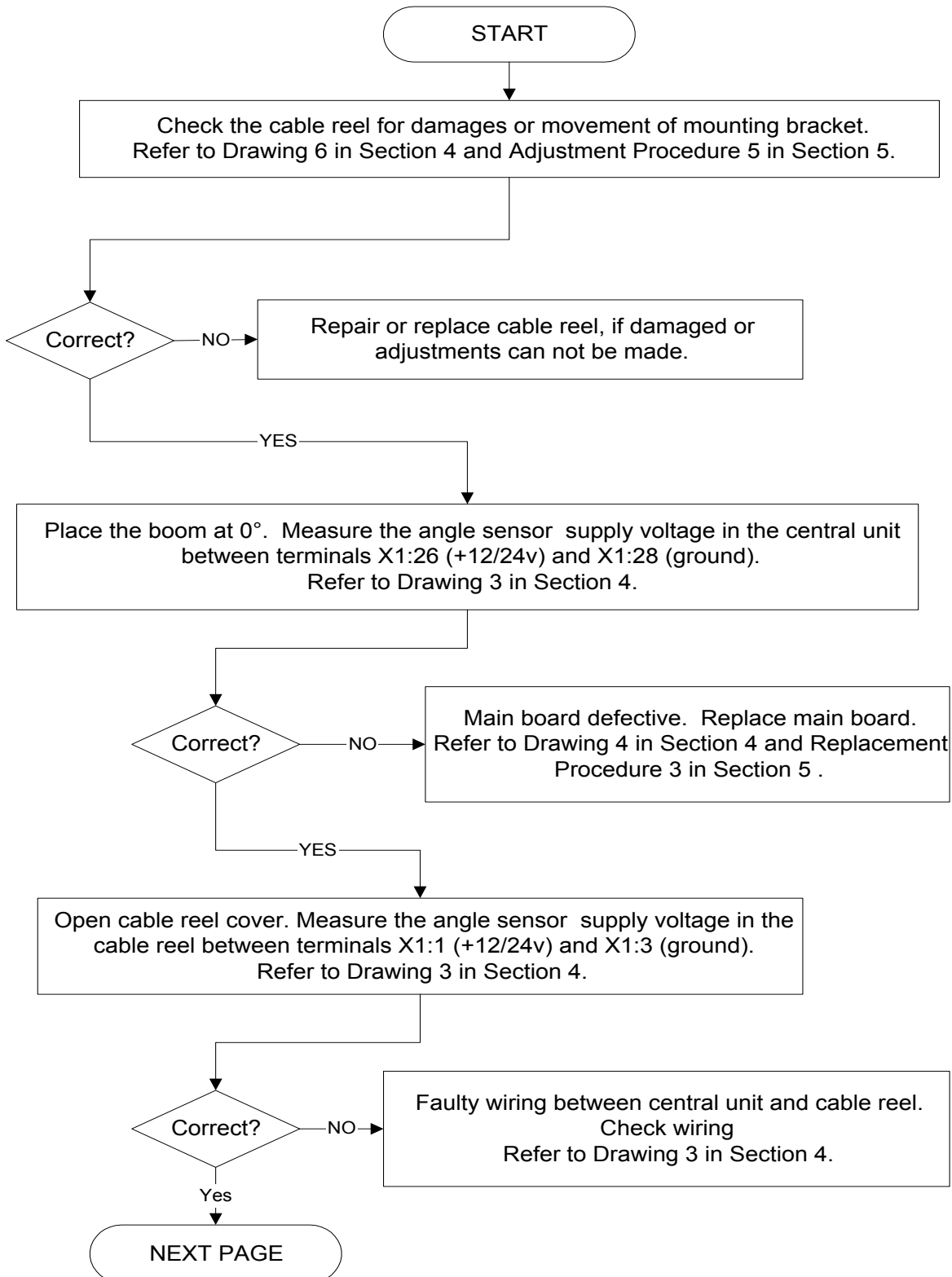

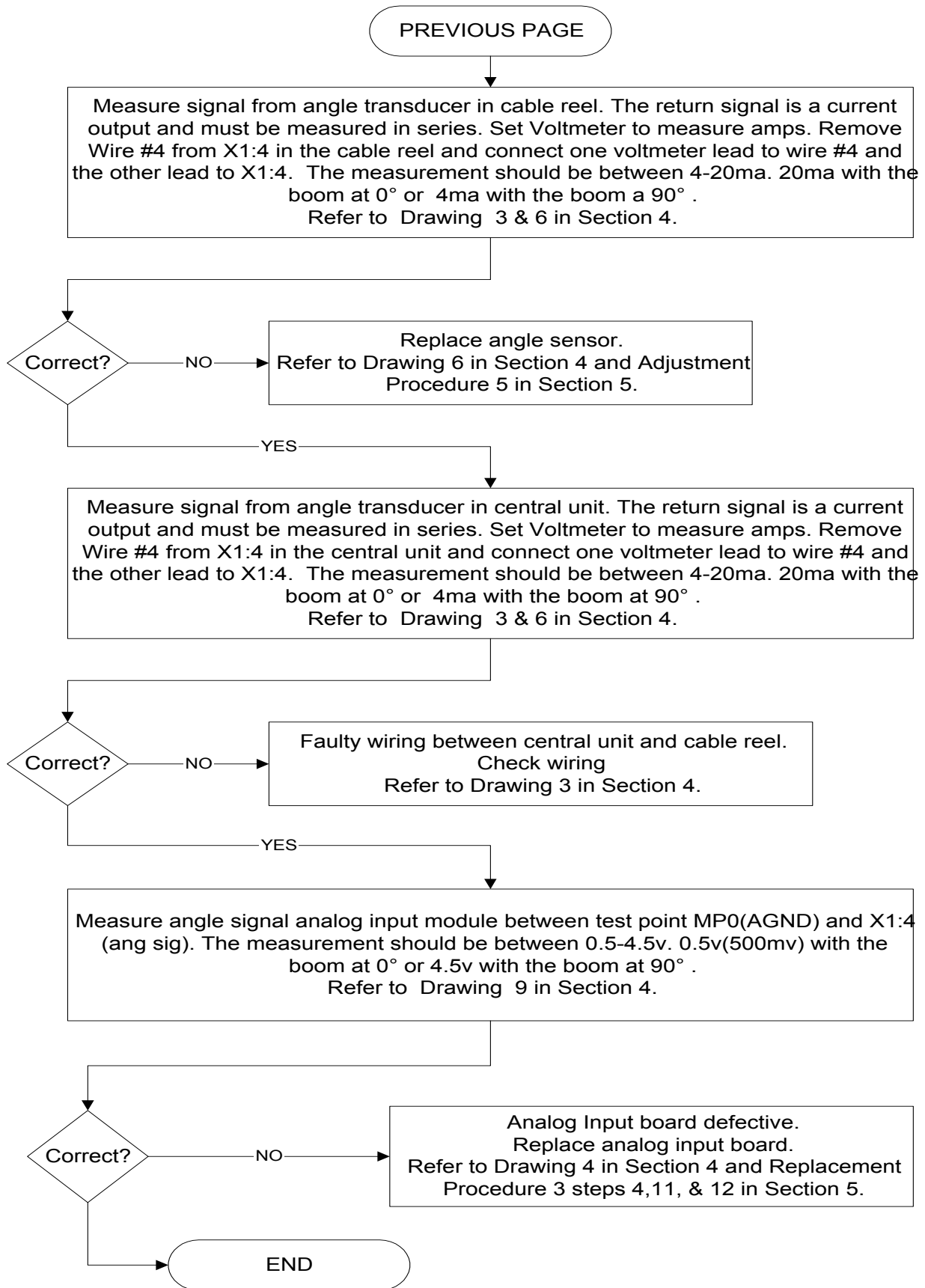

### 3.9 LOAD READING PROBLEM

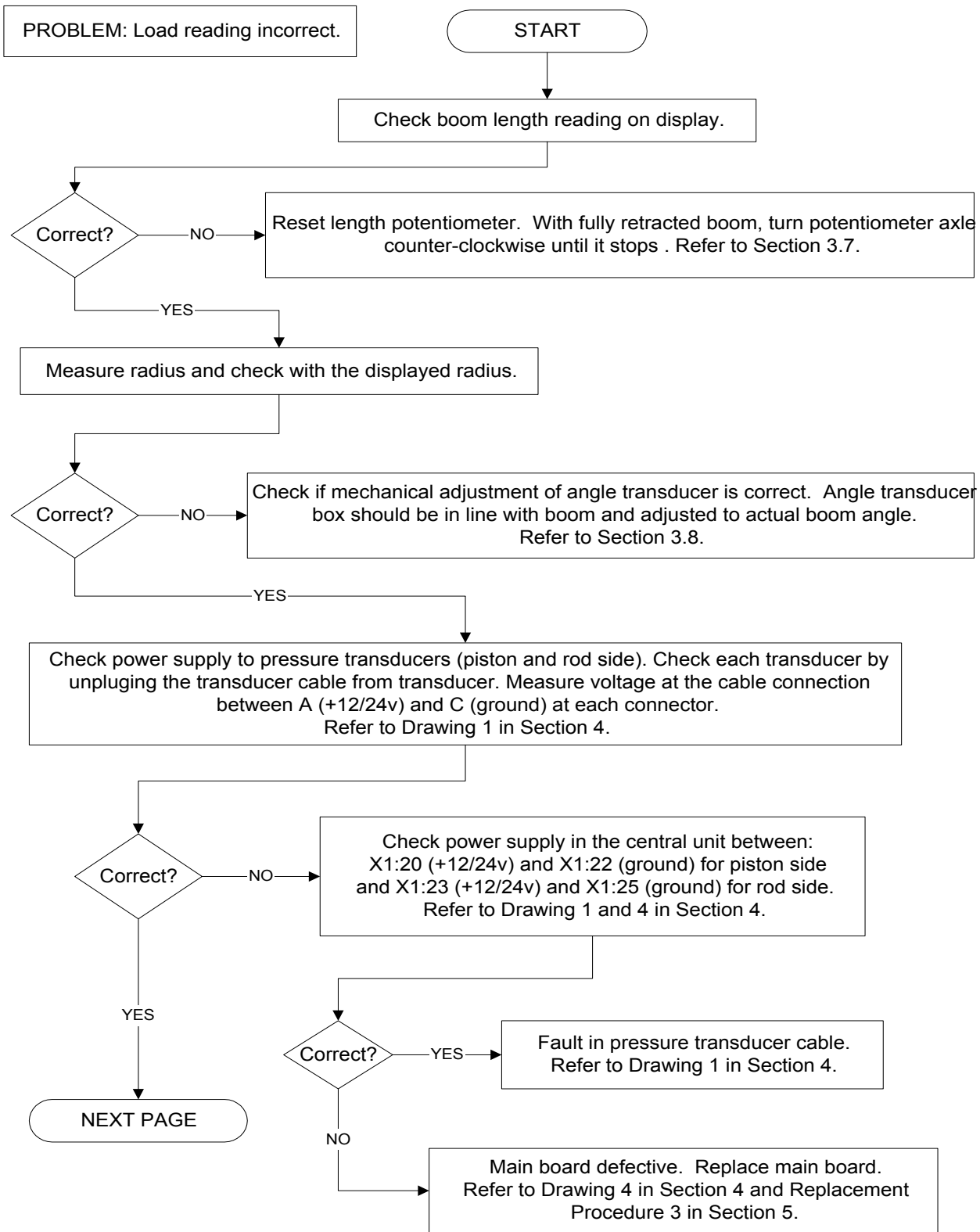



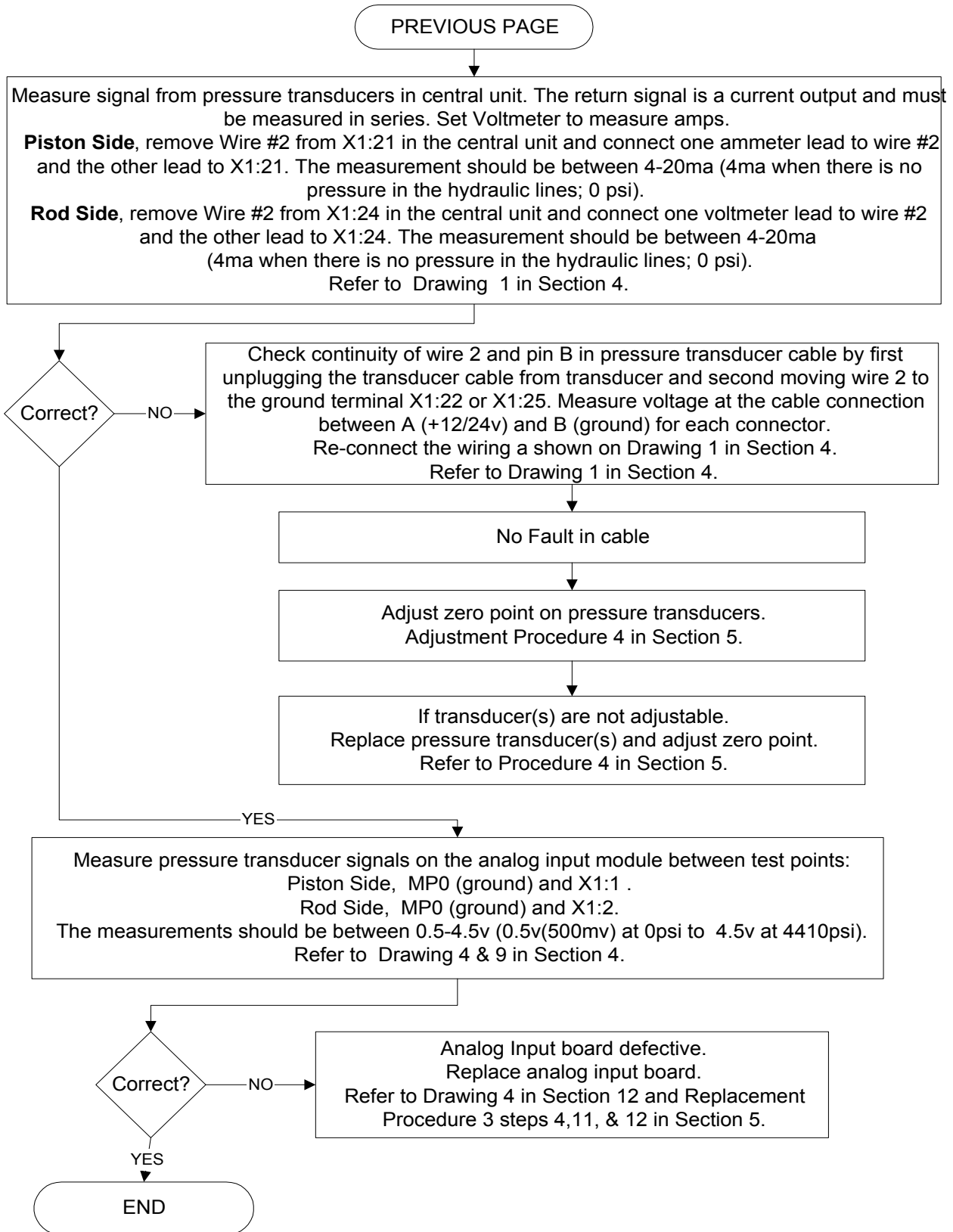

### 3.10 BAD DATA TRANSFER BETWEEN CONSOLE & CENTRAL UNIT OR INTERFERENCE PROBLEM

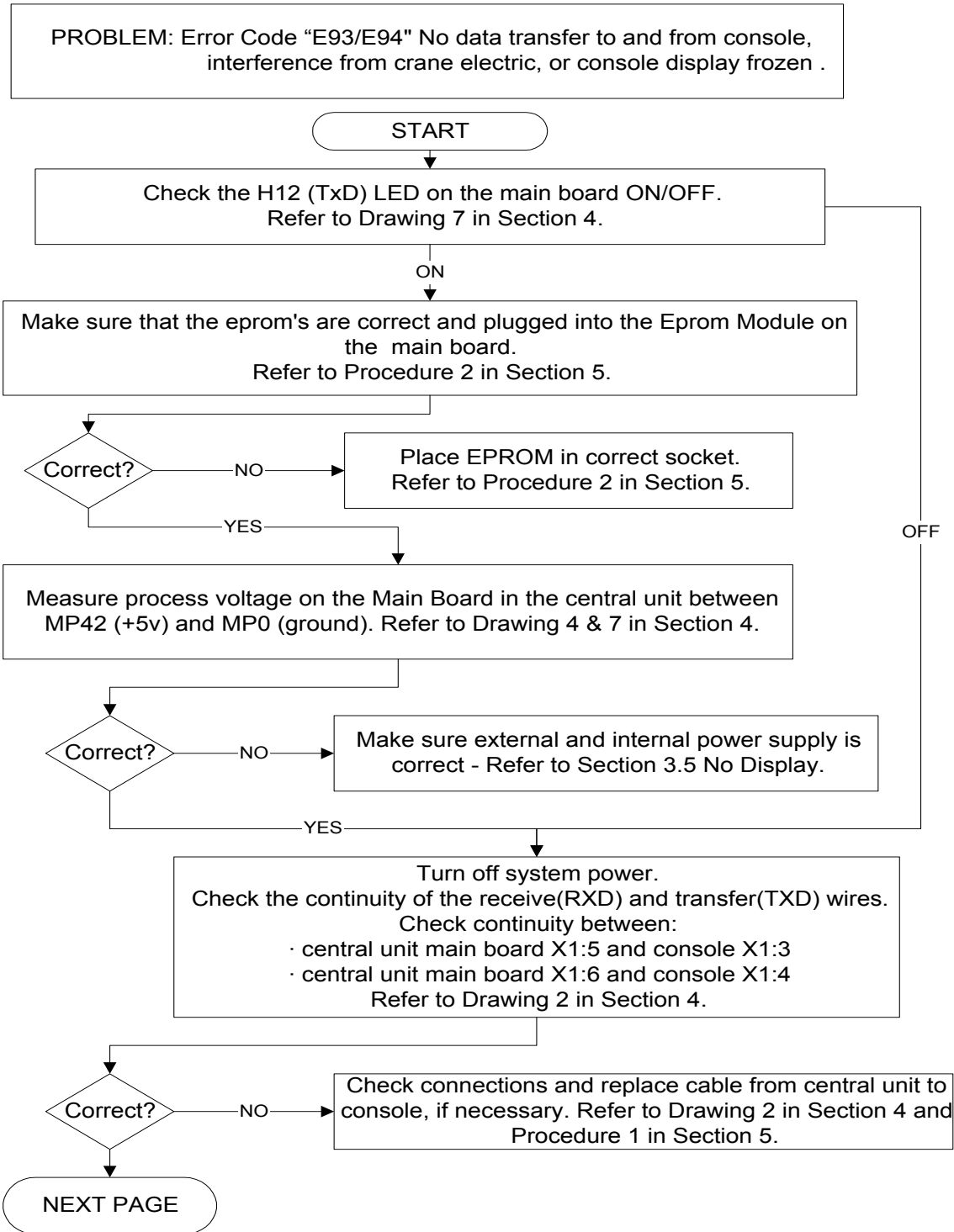

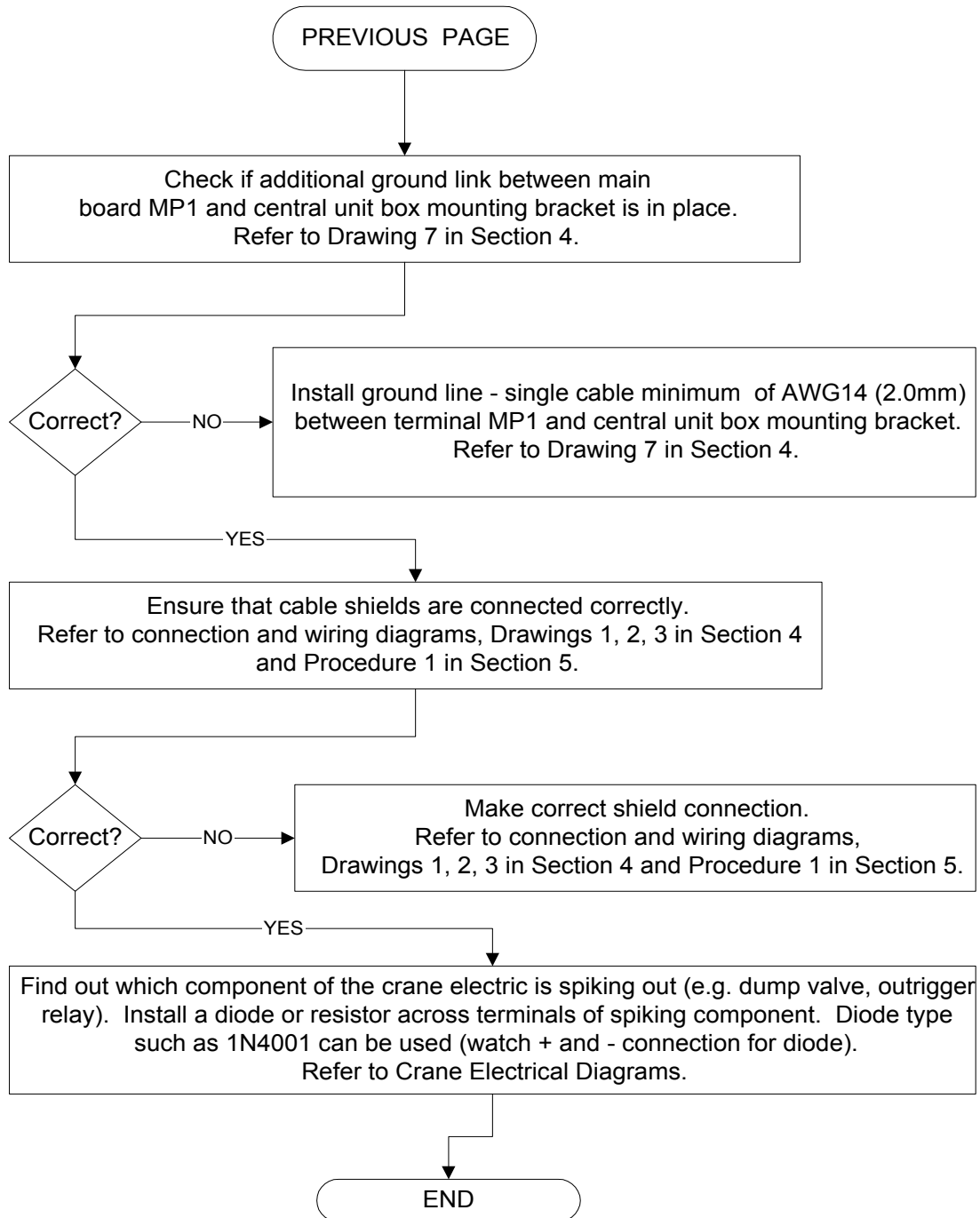

### 3.11 SLEWING ANGLE READING PROBLEM

PROBLEM: Slew Angle displayed incorrect.

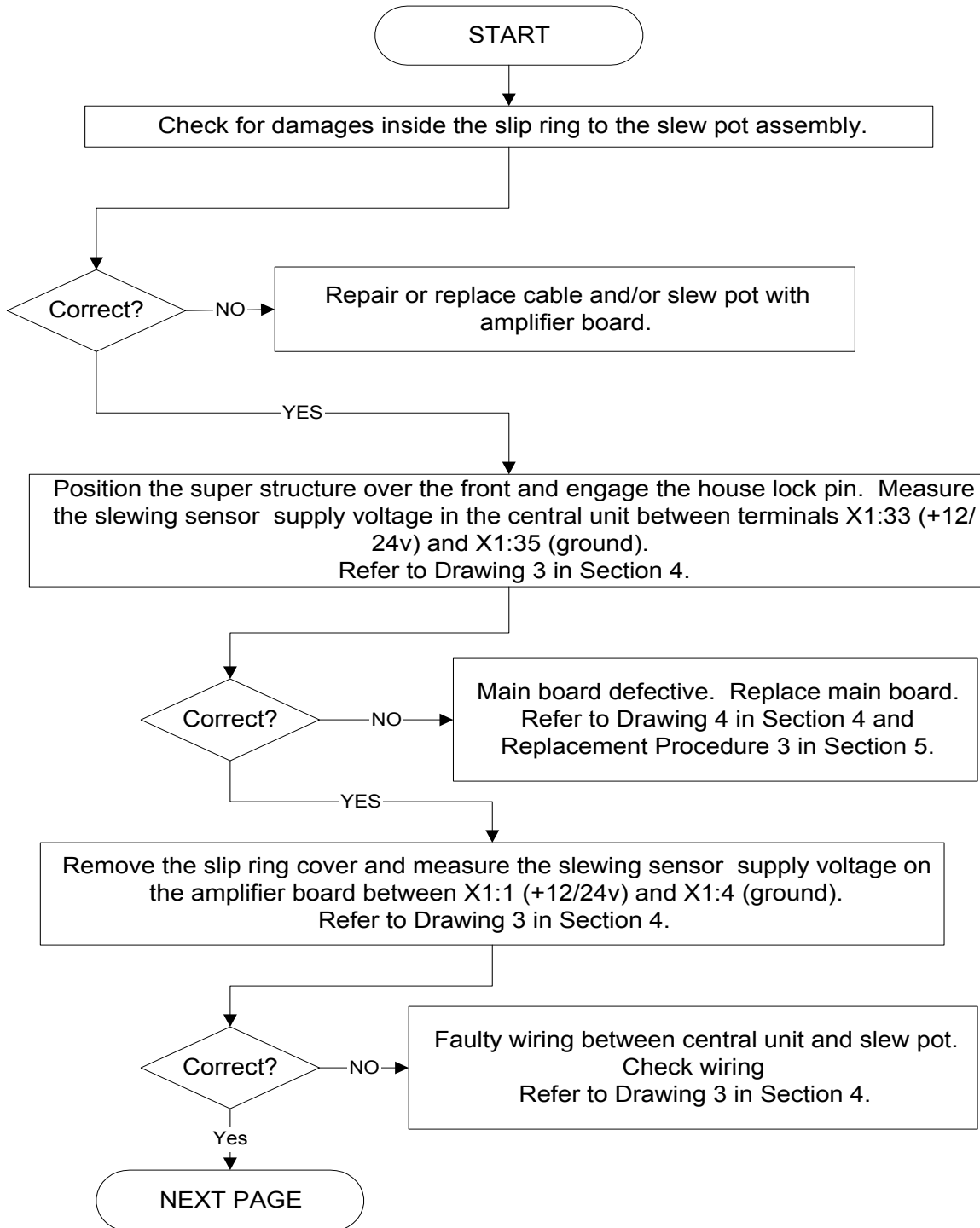

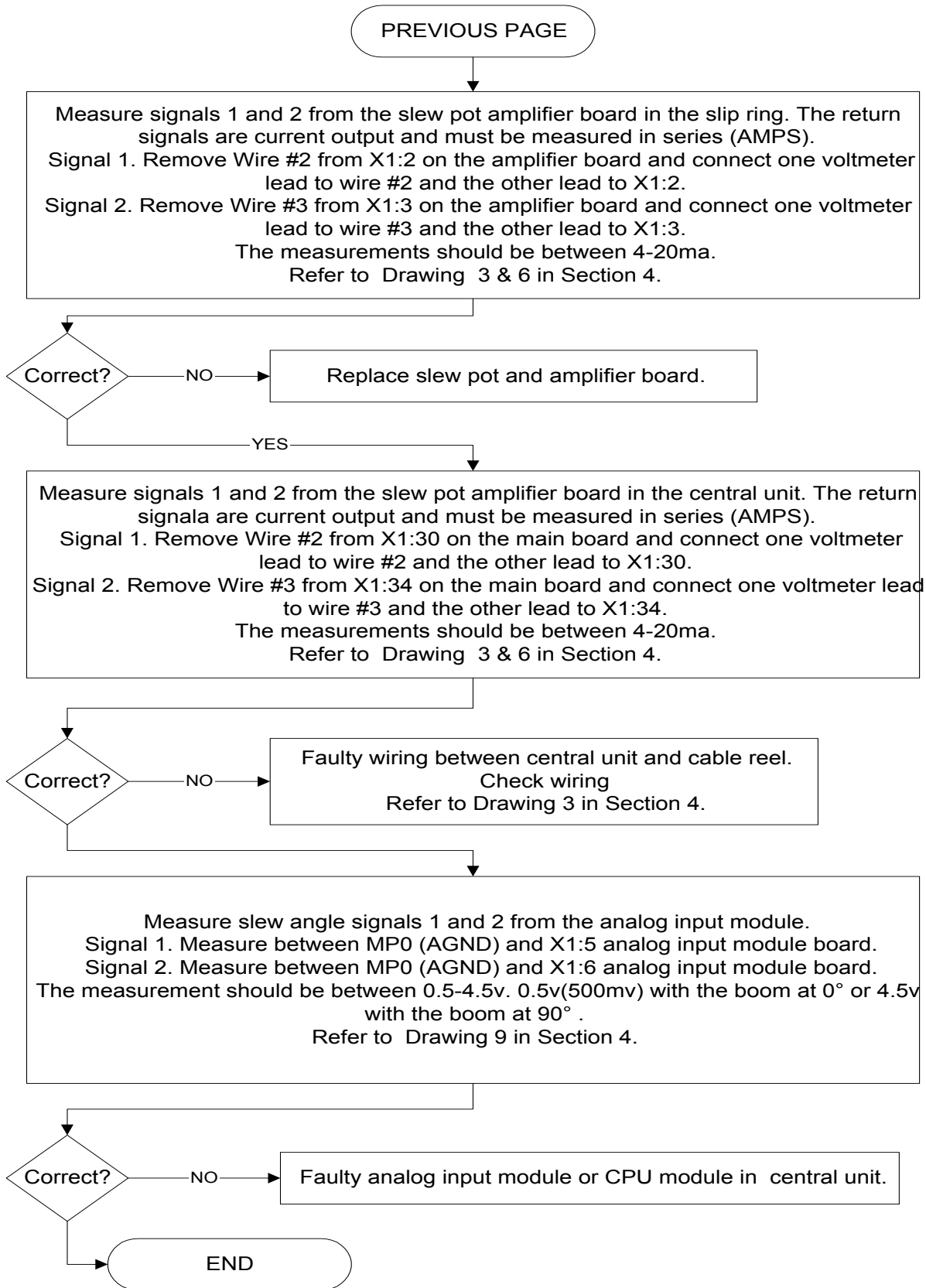

## 4 DRAWINGS

### 4.1 DRAWING 1. ELECTRICAL WIRING FOR CENTRAL UNIT TO PRESSURE TRANSDUCERS AND CRANE

CENTRAL UNIT DS350GM

MAIN BOARD: PAT 024-352-300-001 / GROVE 9-333-103287

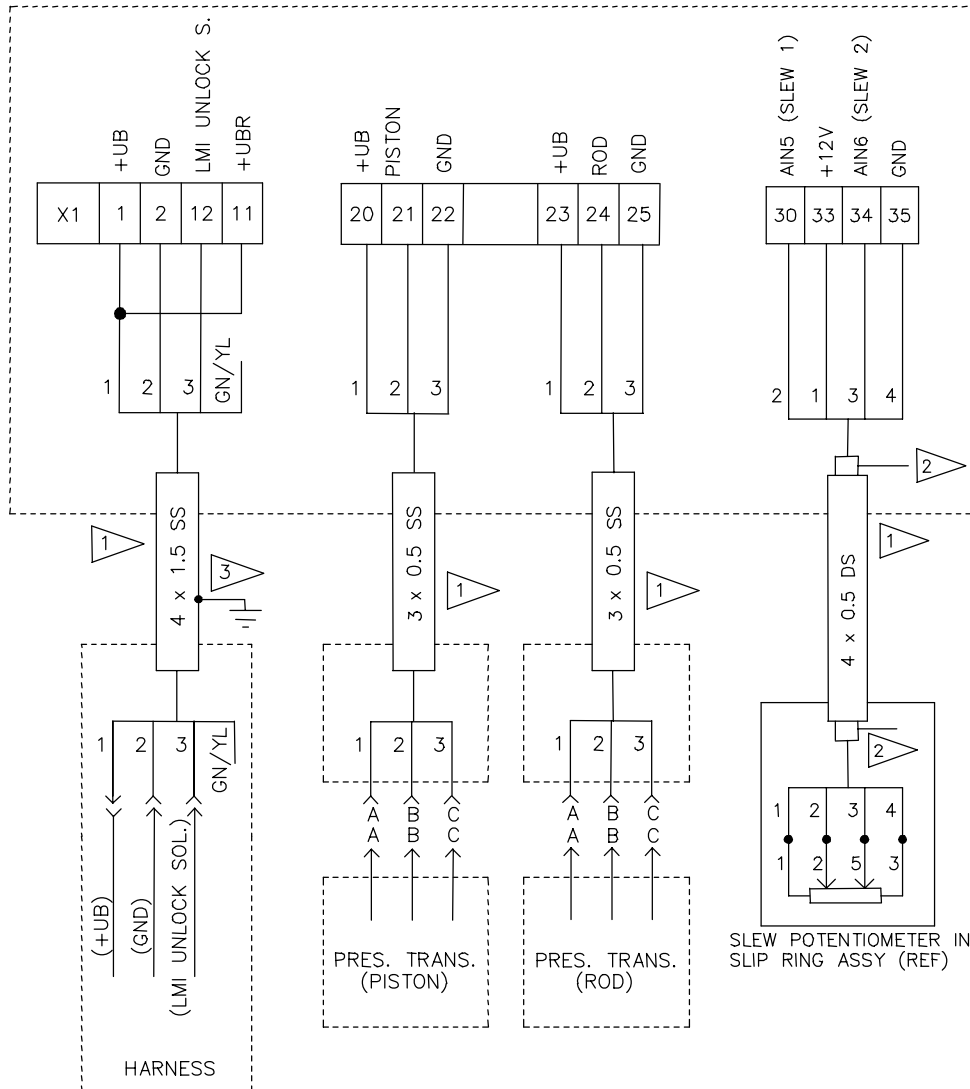

## 4.2 DRAWING 2. ELECTRICAL WIRING FOR CENTRAL UNIT TO CONSOLE

CENTRAL UNIT DS350GM

MAIN BOARD: PAT 024-352-300-001 / GROVE 9-333-103287

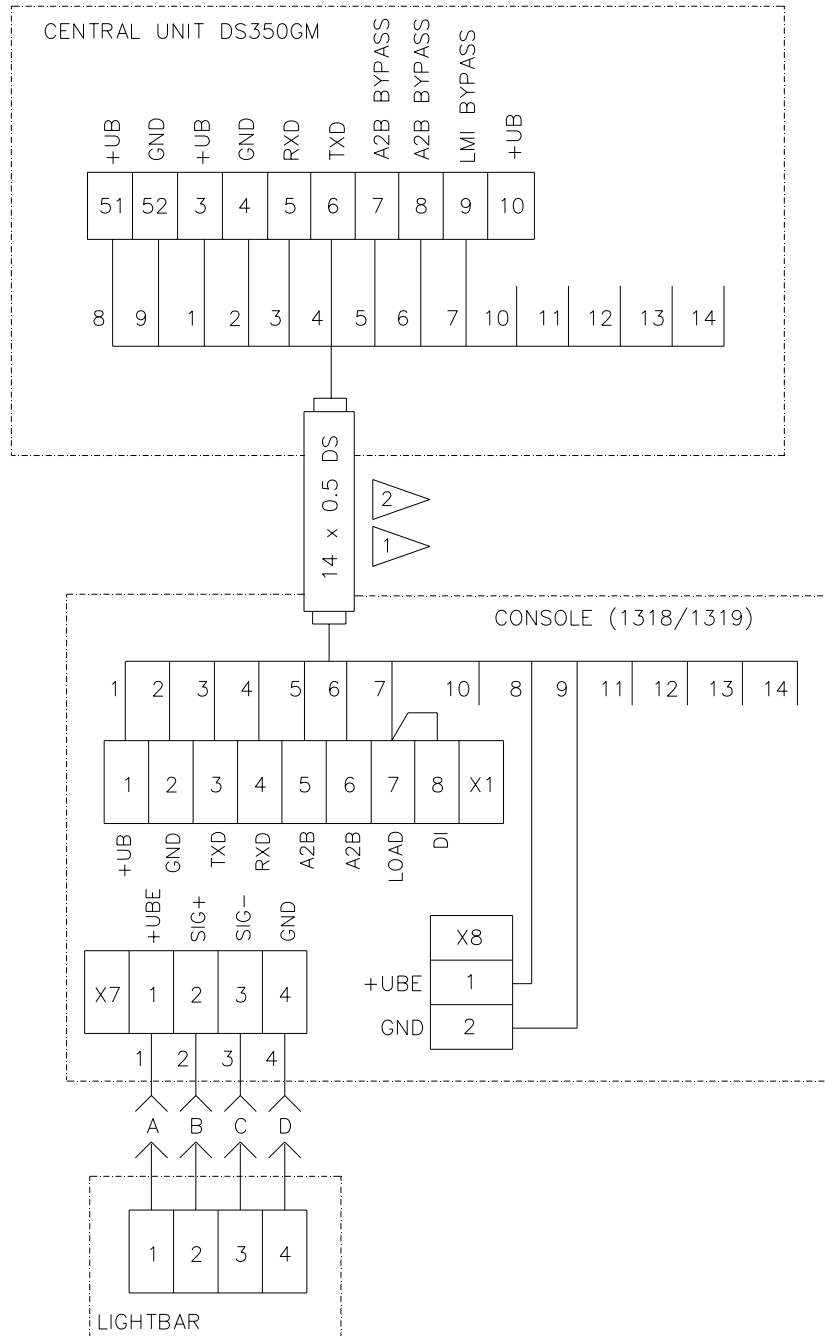

See reference notes on Drawing 1.

### 4.3 DRAWING 3. ELECTRICAL WIRING FOR CENTRAL UNIT TO CABLE REEL/ANTI-TWO BLOCK

CENTRAL UNIT DS350GM  
 MAIN BOARD: PAT 024-352-300-001 / GROVE 9-333-103287

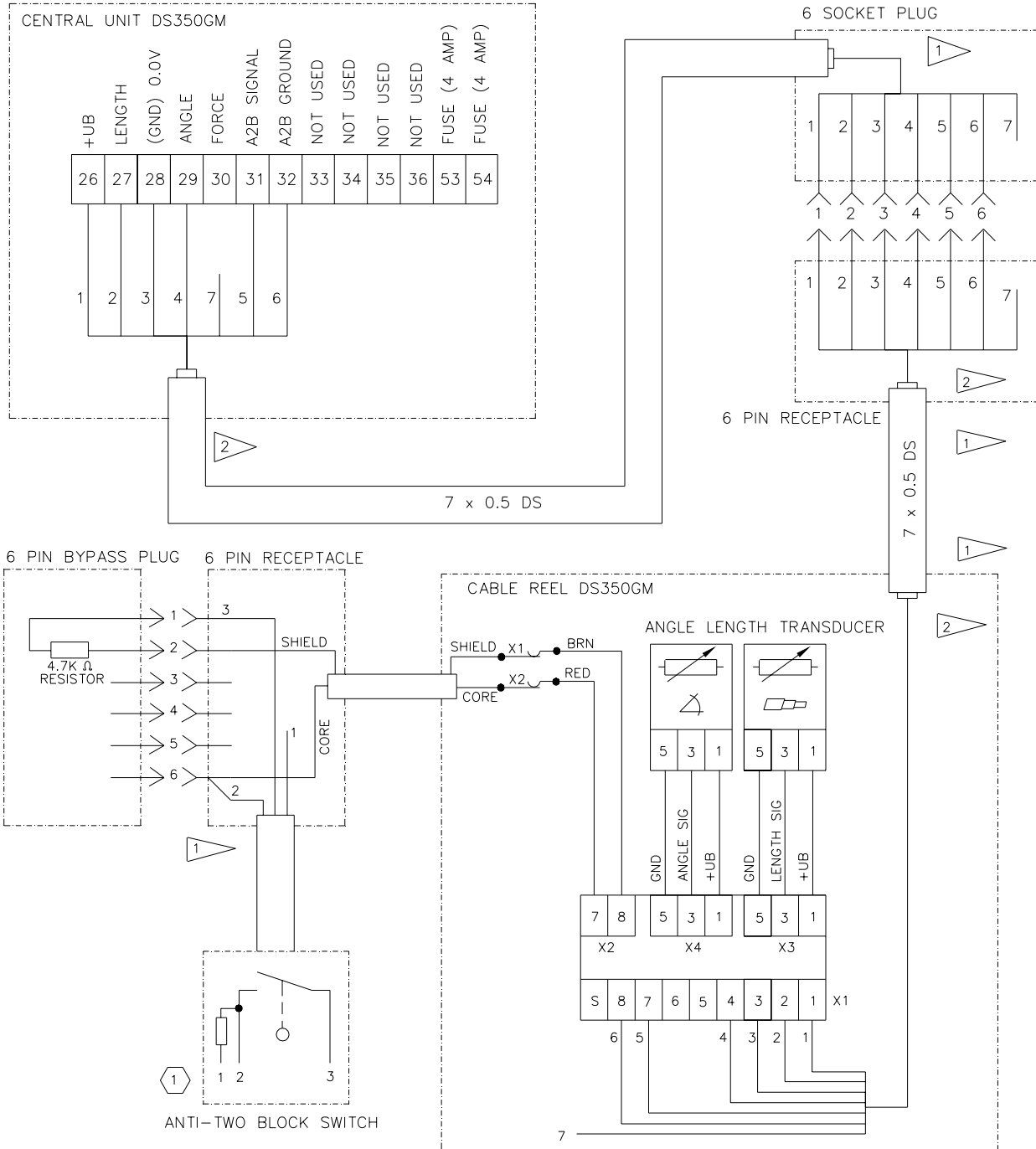



#### 4.4 DRAWING 4. CENTRAL UNIT - PARTS LIST

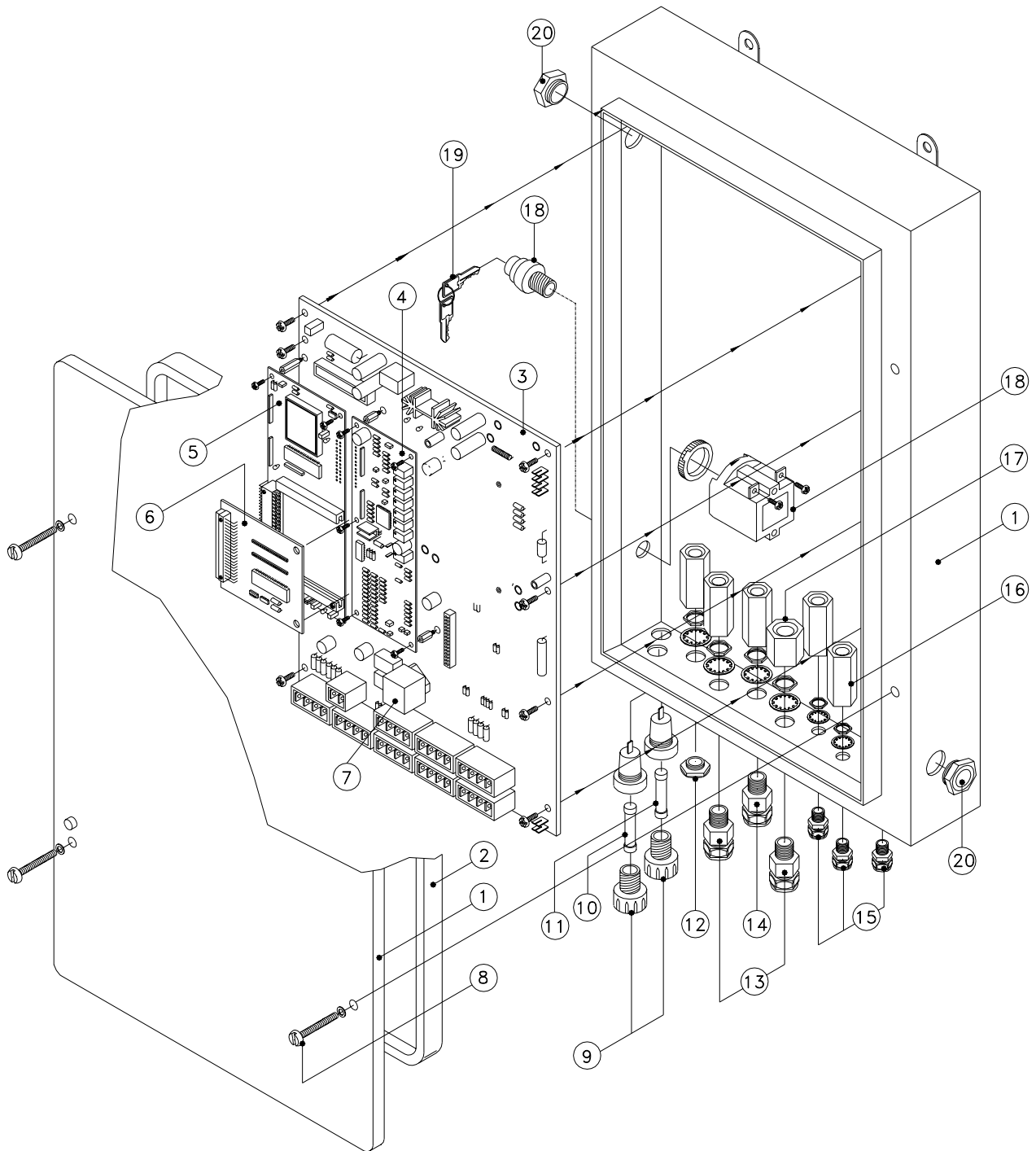

Item 21 digital output board, refer to section 6.6 for location.

## DRAWING 4. CENTRAL UNIT - PARTS LIST - continued

**PART NO. A) PAT 024-350-063-001 / GROVE 9-333-103280 (12V)****PART NO. B) PAT 024-350-063-002 / GROVE 9-333-103281 (24V)**

<b>NO.</b>	<b>PART NO. PAT / GROVE</b>	<b>QTY</b>	<b>DESCRIPTION</b>
01	024-350-050-292 / 9333103549	1	HOUSING W/COVER, CENTRAL UNIT
02	024-350-110-067 / 9333101591	1	GASKET
03	024-352-300-001 / 9333103287	1	MAIN, BOARD
04	024-352-300-020 / 9333103290	1	ANALOG INPUT MODULE
05	024-351-300-007 / 9333103288	1	CPU MODULE
06	024-351-300-011 / 9333103289	1	EPROM MODULE
07A	000-304-140-112 / 9333103550	1	RELAY 12V
07B	000-304-140-241 / 9333101597	1	RELAY 24V
08	024-350-100-135 / 9333101978	1	SCREW SET
09	000-314-022-006 / 9333102542	2	FUSE HOLDER
10	000-313-062-002 / 7482000019	1	FUSE 10amp 250V FAST ACTING
11	000-313-064-001 / 9333103456	1	FUSE 4amp 250V FAST ACTING
12	000-214-340-013 / 9333101732	1	HOLE PLUG, PG13.5
13	021-441-131-013 / 9333101440	2	STRAIN RELIEF, PG13.5 RED/WHT
14	021-441-161-213 / 9333101735	1	STRAIN RELIEF, PG13.5 W/ GREY/WHT
15	021-441-090-709 / 9333101995	3	STRAIN RELIEF, PG9 W/ BLACK/WHITE
16	024-000-100-260 / 9333103315	5	FERRITE FILTER PG13.5
17	024-000-100-261 / 9333103551	1	FERRITE FILTER PG16
18	024-350-100-661 / 9333102541	1	KEYSWITCH
19	031-300-101-131 / 9333103058	1	SPARE KEY
20	024-000-100-095 / 9333103532	2	MEMBRANE ELEMENT, BREATHER
21	024-352-300-041 / 9333103291	1	BOARD, DIGITAL OUTPUT

### 4.5 DRAWING 5A. CONSOLE DS350/1319 - PARTS LIST

GRAPHIC CONSOLE (VERTICAL), PARTS LIST  
 PART NO. 050-350-061-319 / 9333103278

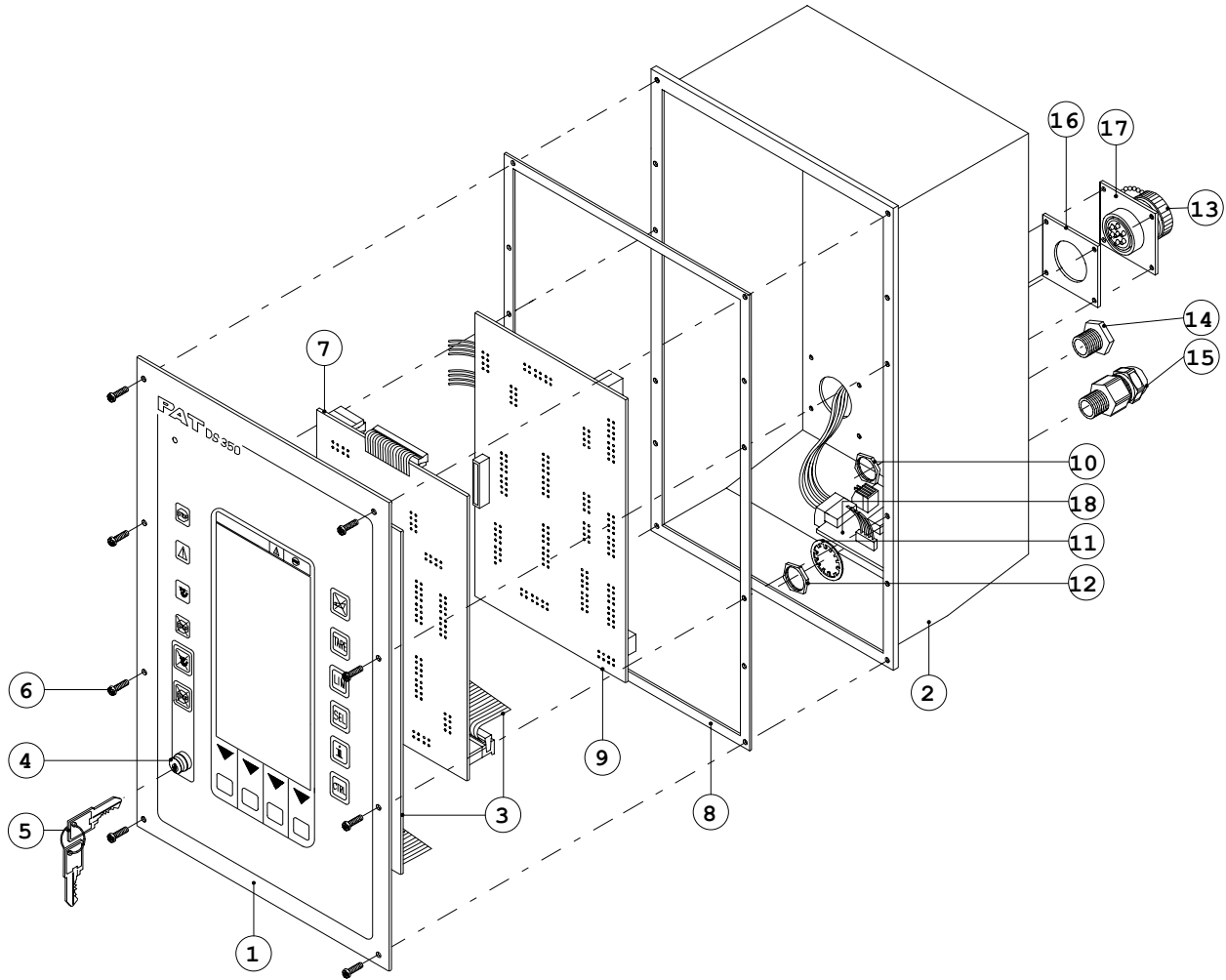

## DRAWING 5A. CONSOLE DS350/1319 - PARTS LIST - continued

**GRAPHIC CONSOLE (VERTICAL), PARTS LIST**  
**PART NO. PAT 050-350-061-319 / GROVE 9-333-103278**

<b>NO.</b>	<b>PART NO. PAT / GROVE</b>	<b>QTY</b>	<b>DESCRIPTION</b>
01	031-300-110-048 / 9333103587	1	CONSOLE ACCY, FRONT FACE & DIS.
02	050-000-100-212 / 9333103552	1	HOUSING
03	050-150-300-053 / 9333103302	1	BOARD, PUSHBUTTON SET(KEYBRDS)
04	003-051-905-235 / 9333103406	1	SWITCH, KEY
05	050-350-110-139 / 9333101691	1	KEY, SPARE
06	002-053-806-058 / 9333102359	6	SCREWS, FRONT PANEL MOUNTING
07	050-150-300-050 / 9333103299	1	BOARD
08	050-000-050-625 / 9333103223	1	SEALING, FRONT PANEL
09	050-150-300-051 / 9333103300	1	TERMINAL BOARD
10	000-214-210-011 / 9333101727	1	LOCKNUT, PG11
11	000-208-010-210 / 9333103169	1	TOOTHWASHER, M12
12	000-214-210-013 / 9333101547	1	LOCKNUT, PG13.5
13	031-300-100-392 / 9333103433	1	CANNON CONN., 7-SOCKET RECPT.
14	000-214-340-011 / 9333102047	1	HOLE PLUG PG11
15	021-448-161-213 / 9333102746	1	STRAIN RELIEF, PG13.5 GREY/WHT
16	031-300-100-173 / 9333103226	1	GASKET
17	031-300-100-024 / 9333103227	1	DUST CAP
18	050-350-300-076 / 9333103222	1	BOARD, TERMINAL INTERFACE FOR LIGHTBAR

4.6 DRAWING 5B. CONSOLE DS350/1318 - PARTS LIST

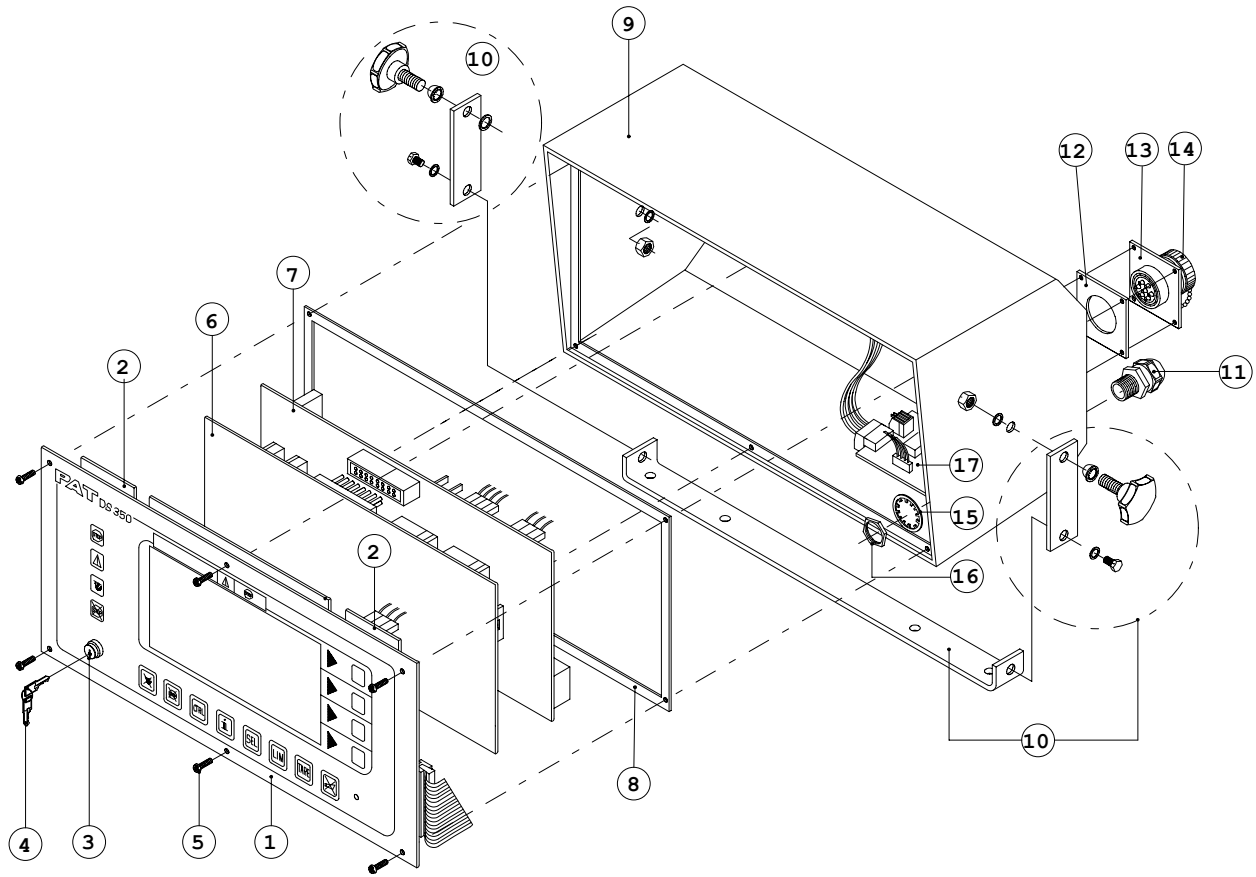

## DRAWING 5B. CONSOLE DS350/1318 - PARTS LIST - continued

**GRAPHIC CONSOLE (HORIZONTAL), PARTS LIST**  
**PART NO. PAT 050-350-061-318 / GROVE 9-333-103279**

<b>NO.</b>	<b>PART NO. PAT / GROVE</b>	<b>QTY</b>	<b>DESCRIPTION</b>
01	031-300-110-049 / 9333103588	1	CONSOLE ACCY, FRONT FACE & DIS.
02	050-150-300-052 / 9333103301	1	BOARD, PUSHBUTTON SET(KEYBRDS)
03	003-051-905-235 / 9333103406	1	SWITCH, KEY
04	050-350-110-139 / 9333101691	1	KEY, SPARE
05	002-053-703-101 / 9333102298	6	SCREWS, FRONT PANEL MOUNTING
06	050-150-300-050 / 9333103299	1	BOARD
07	050-150-300-051 / 9333103300	1	TERMINAL BOARD
08	050-000-050-625 / 9333103223	1	SEALING, FRONT PANEL
09	050-000-100-180 / 9333103439	1	HOUSING
10	050-350-110-263 / 9333103225	1	MOUNTING KIT FOR HOUSING
11	021-448-161-213 / 9333102746	1	STRAIN RELIEF, PG13.5 GREY/WHT
12	031-300-100-173 / 9333102482	1	GASKET
13	031-300-100-392 / 9333103043	1	CANNON CONN., 7-SOCKET RECPT.
14	031-300-100-024 / 9333102612	1	DUST CAP
15	000-208-010-210 / 9333103169	1	TOOTHWASHER, M12
16	000-214-210-013 / 9333101547	1	LOCKNUT, PG13.5
17	050-350-300-076 / 9333103222	1	BOARD, TERMINAL INTERFACE FOR LIGHTBAR

4.7 DRAWING 6. CABLE REEL - PARTS LIST

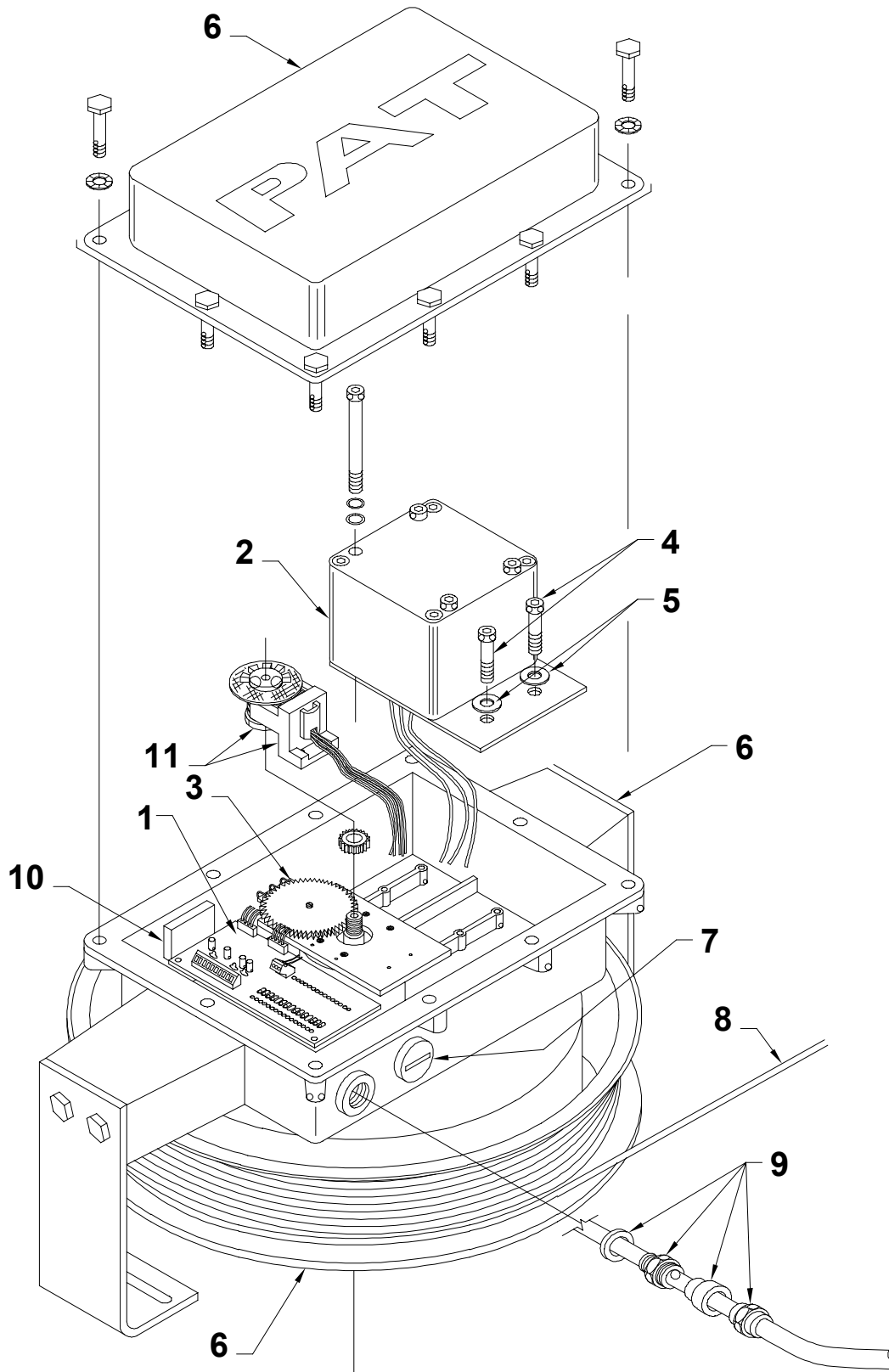

## DRAWING 6. CABLE REEL - PARTS LIST - continued

**CABLE REEL ASSEMBLY, PARTS LIST**  
**PART NO. PAT 068-308-060-001 / GROVE 9333103306**

<b>NO.</b>	<b>PART NO. PAT / GROVE</b>	<b>QTY</b>	<b>DESCRIPTION</b>
01	068-000-300-060 / 9333103309	1	BOARD, TERMINAL W/ EMC FILTERS
02	064-103-060-007 / 9333103303	1	ANGLE SENSOR WG103/0007
03	068-000-300-018 / 9333103308	1	LENGTH POTENTIOMETER UNIT
04	002-050-206-012 / 7121152154	2	SCREW M6 X 12 HEX SOCKET CAP
05	000-207-010-064 / 9333101567	2	WASHER M6 FLAT
06	068-000-100-152 / 9333103376	1	HOUSING KT200
07	000-214-340-013 / 9333101732	1	PG13.5 HOLE PLUG
08	000-673-020-002 / 9333102382	139'	CABLE, LENGTH SINGLE CORE
09	002-148-131-013 / 9333102477	1	STRAIN RELIEF, PG13.5 RED/WHT
10	031-300-100-206 / 7296000504	1	CHEMICAL, CORROSION INHIBITOR
11	068-000-100-064 / 9333102732	1	SLIP RING ASSEMBLY 2 POLE



### 4.8 DRAWING 7. CENTRAL UNIT MAIN BOARD LAYOUT

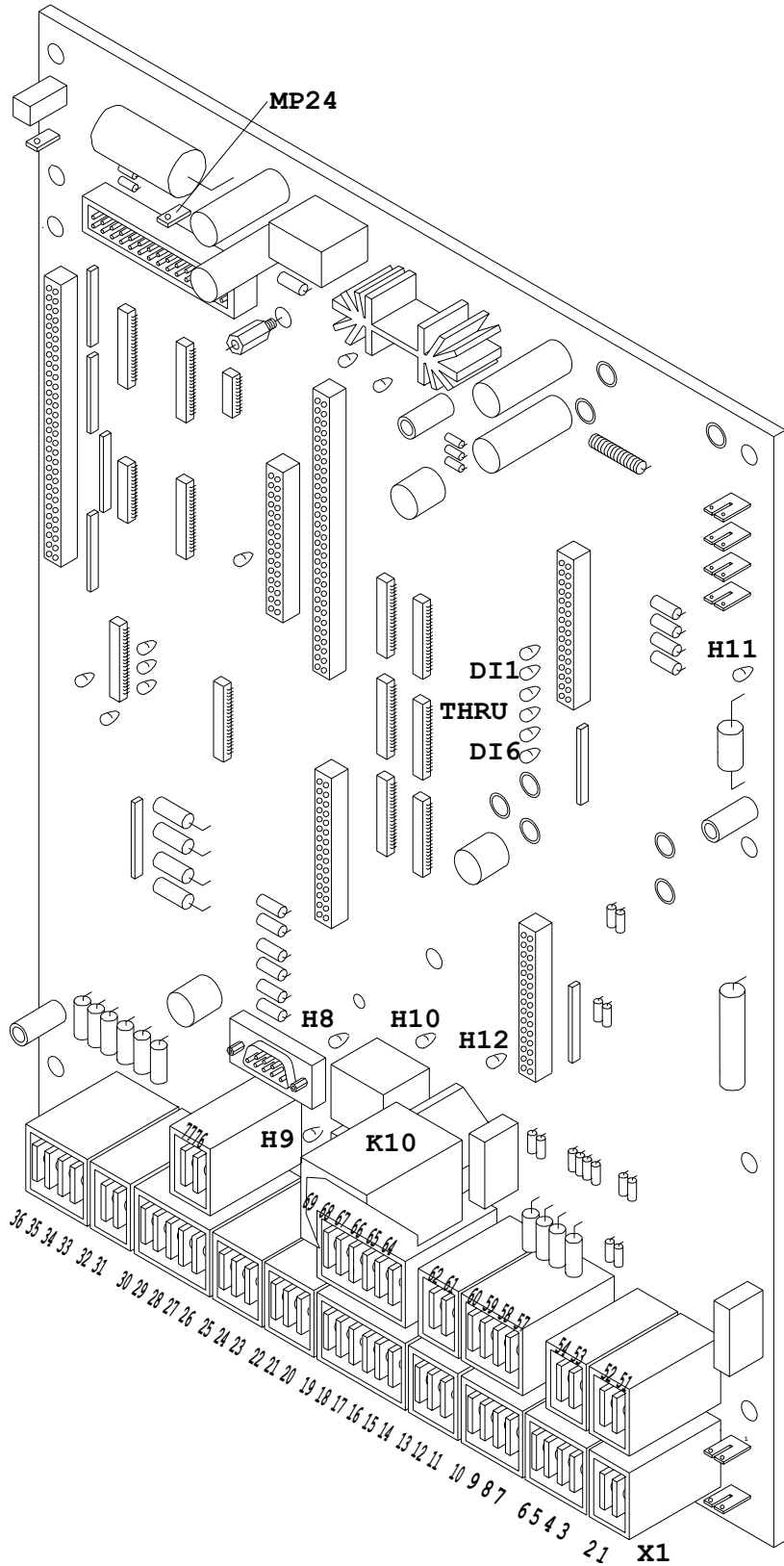

BOARD P/N  
024-352-300-001  
9333103287

- MP1 = KGND
- MP4 = +5V
- MP8 = +9V
- MP9 = +6V
- MP24 = +BATT
- MP25 = +UBS console, sensors, DI's
- MP26 = GND
- MP29 = +5V hand terminal

- MP26 LED'S
- MP4 H08 - LOAD
- MP9 H09 - A2B
- MP8 H10 - MAIN IN/OUT
- H11 H11 - POWER
- H12 H12 - TxD

### 4.9 DRAWING 8. CONSOLE CONNECTION BOARD

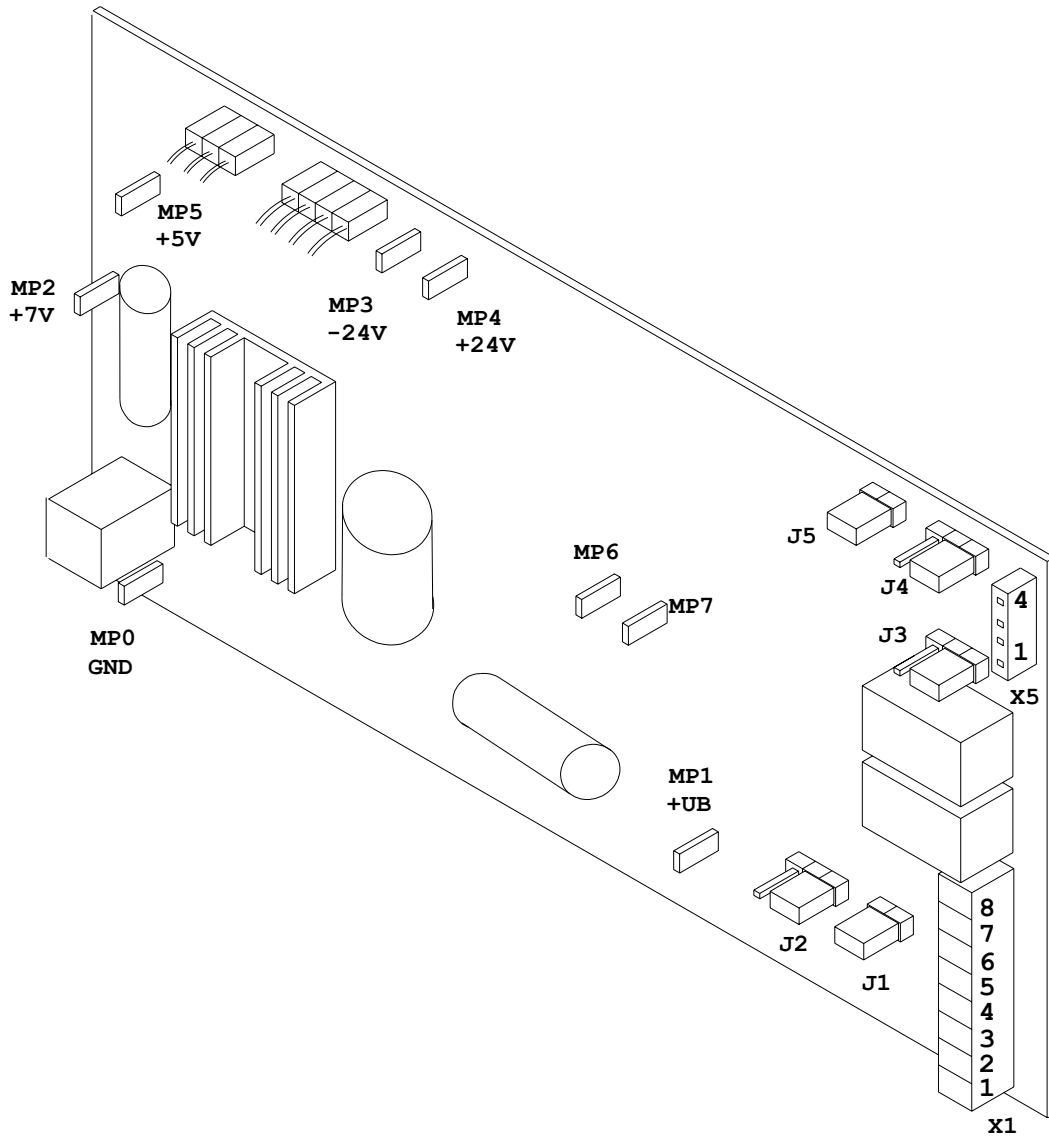

BOARD PART NUMBER 050 150 30 0051 / 9333103300

### 4.10 DRAWING 9. CENTRAL UNIT ANALOG INPUT MODULE

BOARD P/N 024-352-300-020 / 9333103290

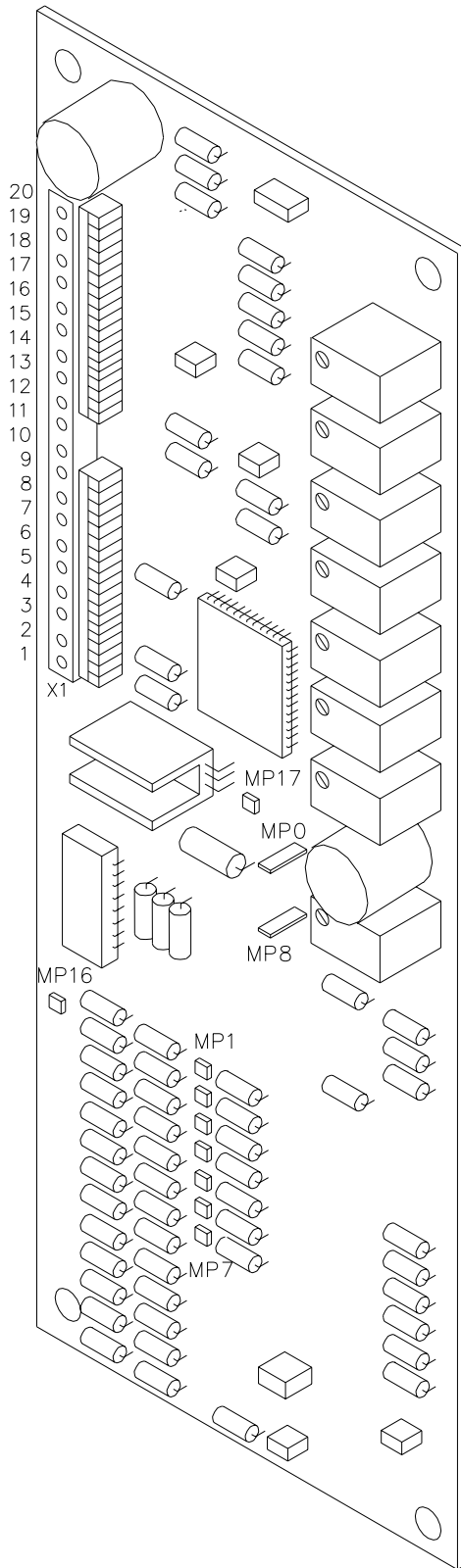

X1:1-7 = ADC INPUT 0.5V...4.5V, Note: If channel adjustments are made through the software and graphic console, DO NOT adjust offset with P1-P7.

X1:8 = TEMP (0.5V + 10mV/°C)

X1:9 = VREFA = 5.000V reference

X1:10 = AGND (reference GND)

X1:11 = VREF+ = 5.0V power ADC

X1:12-15 = CH01-04, DIN1-4 / 10

X1:16 = CH05, +UBS / 10

X1:17 = CH06, HESIN(A2B) \* 4

X1:18 = CH07, +9V \* 4

X1:19 = CH08, VREFA / 2 = 2.500V

X1:20 = UKLEMM, app. VREFA, limits ADC input to 5.0V

MP1 = AGND

MP8 = +5V

MP1-7 = Input channels 1-7 0.5V/4mA...2.5V/20mA

MP14 = +13V REF02

MP16 -= HESIN input voltage

MP17 = app 5.4V clamp for inputs

The analog input module converts the sensor signals on channels 1-7 to signals that will be process at the CPU and software. The incoming signal measured at the measuring points (MP) will be 0.5V/4mA...2.5V/20mA. The analog input module then converts the channel signals to 0.5V...4.5V, which can be measured on X1:1 through X1:7.

The signal voltage can be measured at either point using ground and the signal input.

## 5 PROCEDURES

### 5.1 PROCEDURE 1. STRAIN RELIEF INSTALLATION

#### OUTTER SHIELD GROUNDED AT STRAIN RELIEF WITH FERRITE FILTER

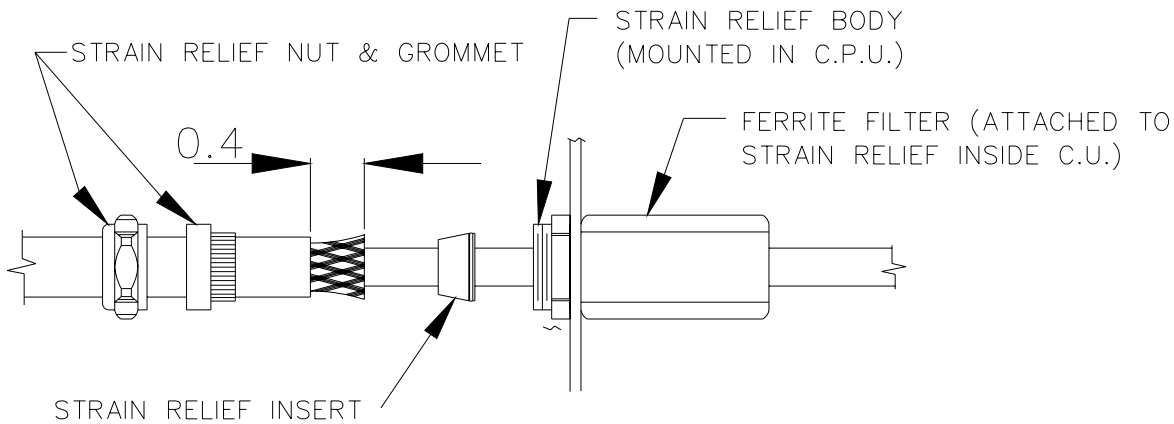

#### INNER SHIELD GROUNDED ON CONNECTION BOARD

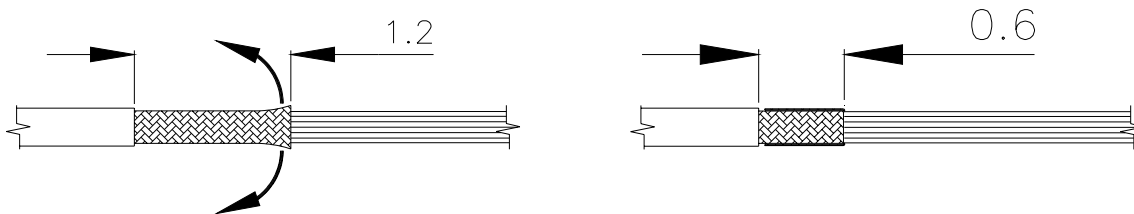

CUT INNER SHIELD BACK TO APPROXIMATELY 1.2 INCH.  
THEN FOLD INNER SHIELD BACK TO INNER JACKET,  
SO THE INNER SHIELD IS 0.6 INCHES IN LENGTH.

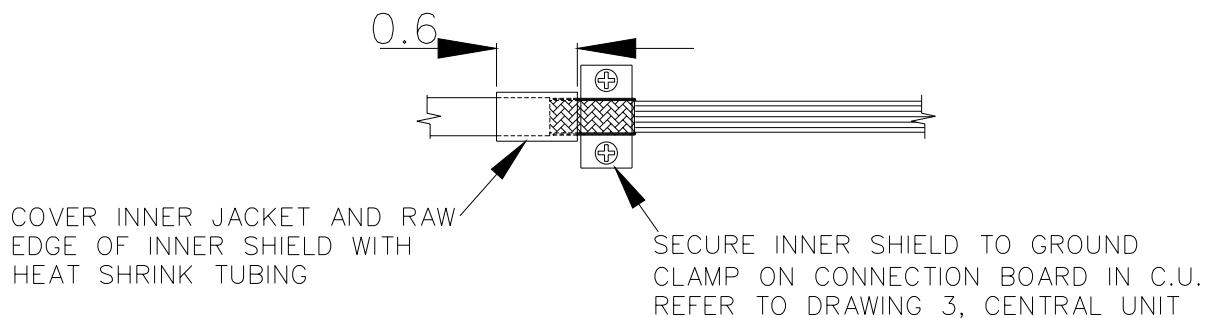

## 5.2 PROCEDURE 2. EPROM LOCATION AND INSTALLATION

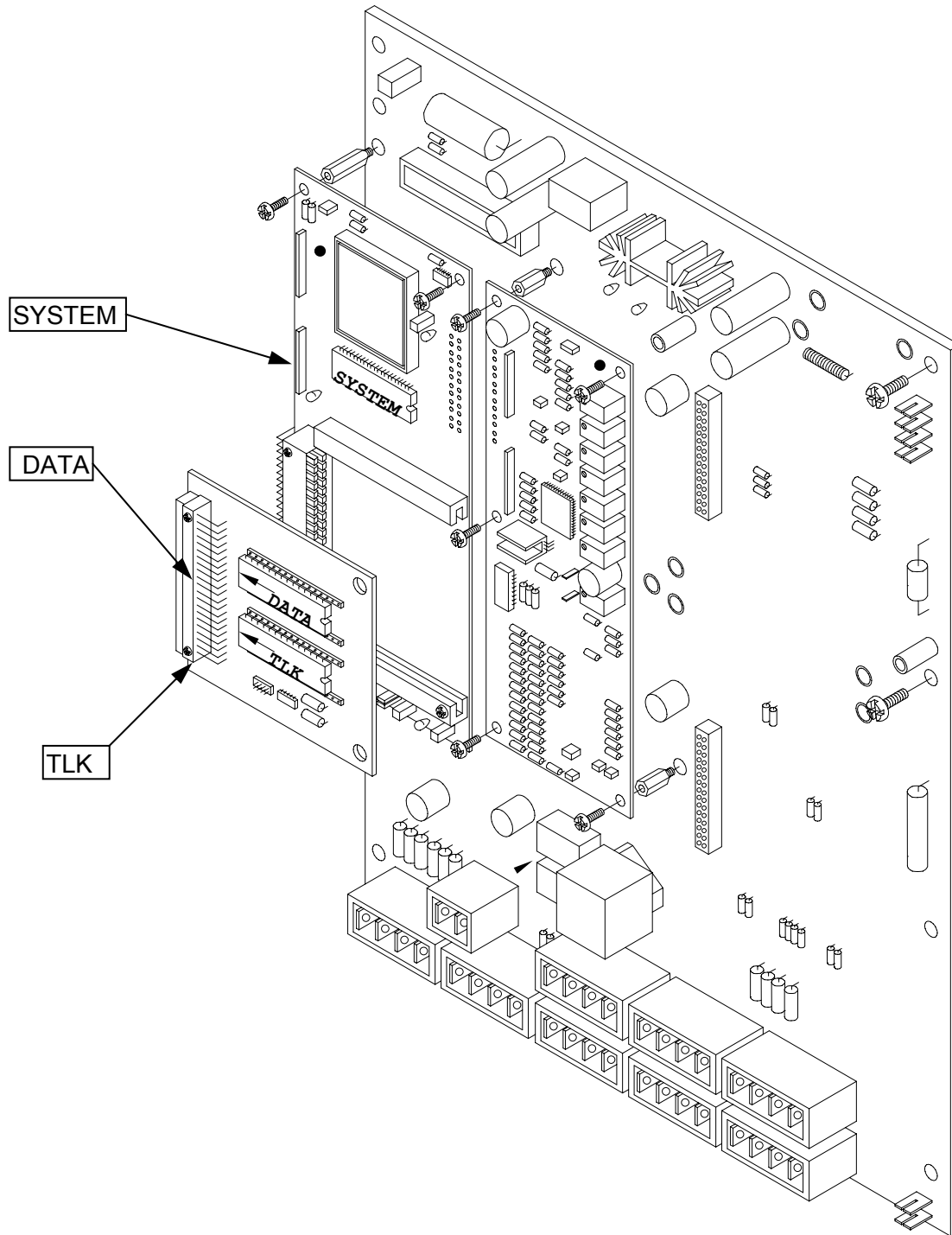

- Ensure the notch is in the correct direction.
- The DATA and TLK EPROMs fill the bottom of the socket as shown by the arrows.
- Place EPROMs in the correct EPROM socket as shown.

### 5.3 PROCEDURE 3. MAIN BOARD REPLACEMENT

Refer to Drawing 4, central unit parts list for board location.

1. Turn system power off.
2. Remove the central unit lid.

NOTE: Take care not to damage the boards with the screwdriver, when removing and inserting screws.

NOTE: Use care when lifting the CPU module board and analog input module from the main board, due to the fact that these boards have pins on the bottom side which insert into the main board.

3. Remove CPU module board by taking out the 4 small Philips screws holding it in place.
4. Remove analog input module board by taking out the 6 small Philips screws holding it in place.
5. Remove the relay from the main board, item 7 on Drawing 4 in Section 4.4.
6. Mark all connection wires before removing, to identify location for reconnecting. Disconnect all X1 terminal wires from the main board.
7. Remove the 14 large Philips screws holding the main board in place.
8. Take notice of the orientation of the main board in the central unit. Remove main board and place in the packing material that the replacement main board came in.
9. Carefully insert the new main board in place. Refer to Drawing 4 in Section 4.4 for location.
10. Insert the 14 Philips mounting screws, be sure to attach the ground wire to the KGND screw in the lower left corner. Refer to Drawing 4.
11. Insert analog input module board by lining up the pins into the sockets X16 and X17 and the 6 screw holes.
12. Insert the 6 small Philips screws and washers.
13. Insert CPU module board by lining up the pins into the sockets X11 and X12 and the 4 screw holes.
14. Insert the 4 small Philips screws and washers.
15. Insert the relay on to the main board, item 7 on Drawing 4.
16. Connect the X1 terminal wires to the main board. Refer to Drawings 1, 2 and 3.
17. Inspect the gasket for nicks, cuts, or damages. Refer to 031-300-340-003 DS 350 Central Unit Gasket Recommendations, Revision - and 031-300-340-002 Central Unit Cover Installation and Tightening Procedure, Revision A.

## 5.4 PROCEDURE 4. PRESSURE TRANSDUCER ZERO ADJUSTMENT

### 5.4.1 USING GRAPHIC CONSOLE FOR ZERO-SETTING OF PRESSURE TRANSDUCER & FORCE INPUTS

The zero setting consists of defining zero-point offset. The zero point offset is added to the transducer measurement to calculate the real physical pressure or force.

To define the zero-point offset the pressure transducer or force sensor must be in equilibrium (no load condition). Therefore the boom must be lowered all the way down (no rest pressure) and the hydraulic hoses disconnected from the pressure transducers.

**CAUTION:** Ensure there is no pressure in the hydraulic line when disconnecting the hoses from pressure transducers.

#### 5.4.1.A ACTIVATING THE ZERO-SETTING FUNCTION

To activate the zero-setting Function, press the INFO key on the console to activate the INFO Function. Now press the CTRL key. At this point, a five digit Authorization Number must be entered. Only authorized personnel may adjust the zero-point settings.

Example: 6 4 3 5 6

#### 5.4.1.B ZERO-SETTING THE TRANSDUCER INPUTS

Now, having successfully entered a valid password, the piston-side zero-point setting function is activated.

The display shows which transducer (piston-side, rod-side or force) is being zeroed and a horizontal dial marks the present pressure (or force) difference in %. By pressing the + key, the input pressure (or force) is adjusted upwards, and by pressing the minus (-)key, the input value is adjusted downwards. When the plus (+) and minus (-) keys are pressed simultaneously, the zero setting occurs automatically. Manual adjustments may be preformed using + or -.

The return key toggles between the piston-side, the rod-side, and the force zero-setting.

When the operator is finished, pressing the EXC or INFO key returns the console display to normal.

## 5.5 PROCEDURE 5. LENGTH AND ANGLE SENSOR ADJUSTMENT

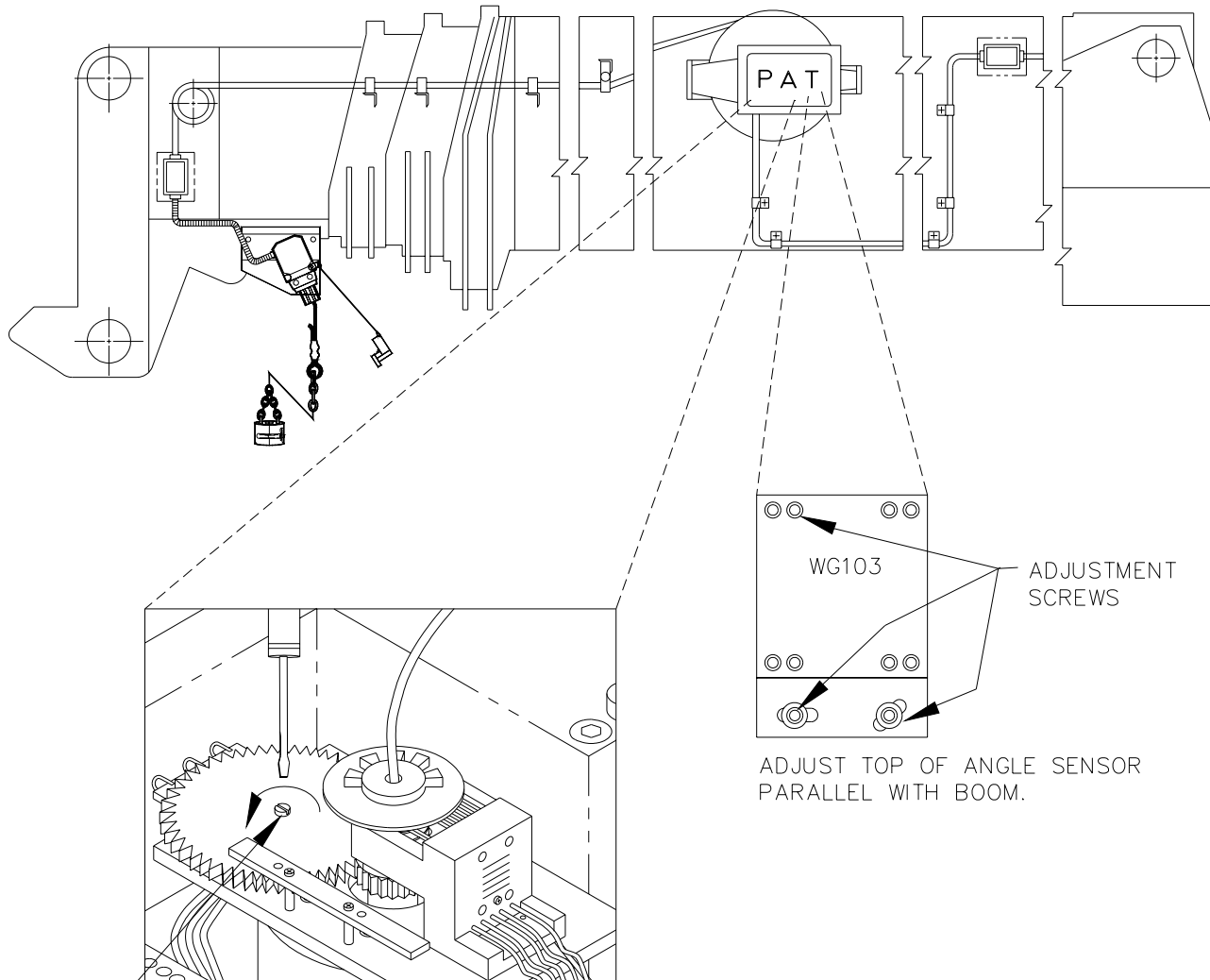

ADJUST LENGTH POTENEIOMETER, WITH BOOM FULLY RETRACTED  
TURN THE CENTER SCREW COUNTER CLOCKWISE TO A SOFT STOP.



---

## 5.6 PROCEDURE 6. SLEW POT POTENTIOMETER ZERO ADJUSTMENT

### 5.6.1 USING GRAPHIC CONSOLE FOR ZERO-SETTING OF SLEW POT POTENTIOMETER

The zero setting consists of defining zero-point offset. The zero point offset is added to the transducer measurement to calculate the real physical pressure or force.

To define the zero-point of the slew potentiometer the super structure must be positioned so the boom is in the zero degree position over the front and the house lock pin engaged.

#### 5.6.1.A ACTIVATING THE ZERO-SETTING FUNCTION

To activate the zero-setting Function, press the INFO key on the console to activate the INFO Function. Now press the CTRL key. At this point, a five digit Authorization Number must be entered. Only authorized personnel may adjust the zero-point settings.

Example: 6 4 3 5 6

Press "Return"

#### 5.6.1.B ZERO-SETTING THE TRANSDUCER INPUTS

Now, having successfully entered a valid password, the piston-side zero-point setting function is activated.

Press return two times to display the slew adjustment screen.

The display shows a scale from -5 to +5 degree, a horizontal mark shows the current position of the slew pot wiper.

By pressing the "+" and "-" keys simultaneously, the zero setting occurs automatically. Note: The indicator line will move to zero on the bar graph.

When the operator is finished, pressing the EXC or INFO key returns the console display to normal.

## 6 THEORY

### 6.1 THEORY 1. OPERATION OF BOOM LENGTH SENSOR

The system sensors provide a 4 to 20mA output; however, due to a fixed resistor circuit in the central unit, the input signal can be measured using ammeter (current) or voltmeter (voltage). The input signal operating window is 4 to 20mA, measured in series at the analog input terminal OR 1.1 to 5.5V, measured in parallel between the analog input and ground (GND) terminals. At 4mA the voltage is 1.1V and at 20mA the voltage is 5.5V. When troubleshooting this system, a current or voltage needs to be measured to determine the status or condition of the sensor.

#### Measuring current:

The ammeter (A) is used to measure current at the length input signal. Remove the wire from X1:27 terminal in the central unit and measure the current with the ammeter in series. The measurement should be between 4..20mA.

#### Measuring voltage:

The voltmeter (V) is used to measure voltage between pins X1:27 (length signal) and X1:28 (gnd) on the main board (024-352-300-001 / 9333103287). The resistors are there to show that at 4mA the voltage is 1.1V because current multiplied with resistance equals voltage; therefore, 4mA x 275 ohms (total resistance) = 1.1V.

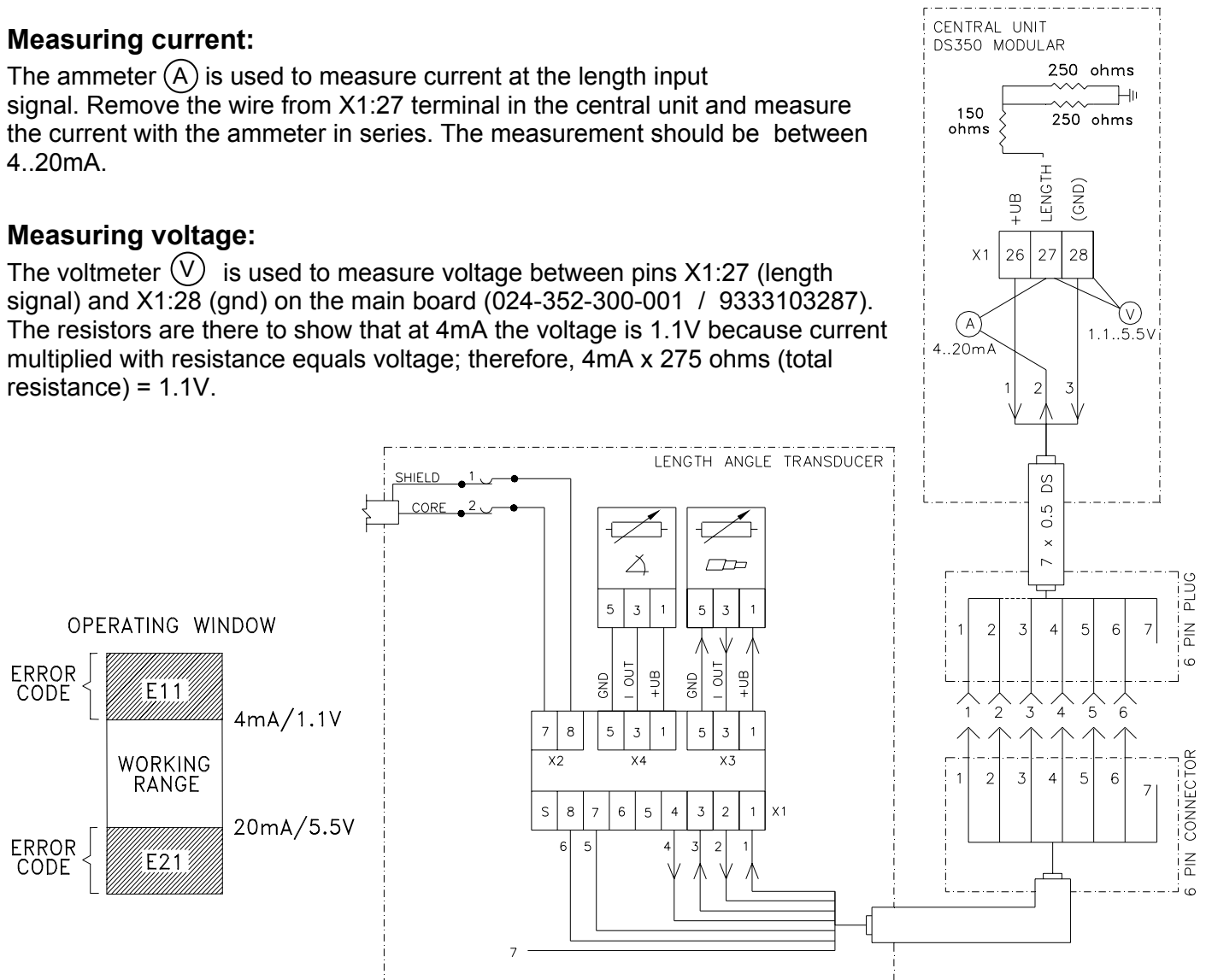

## 6.2 THEORY 2. OPERATION OF PISTON SIDE LOAD SENSOR

### Measuring current:

The ammeter (A) is used to measure current at the piston side input signal. Remove the wire from X1:21 terminal in the central unit and measure the current with the ammeter in series. The measurement should be between 4..20mA.

### Measuring voltage:

The voltmeter (V) is used to measure voltage between pins X1:21 (piston side signal) and X1:22 (gnd) on the main board (024-352-300-001 / 9333103287). The resistors are there to show that at 4mA the voltage is 1.1V because current multiplied with resistance equals voltage; therefore,  $4\text{mA} \times 275\text{ ohms (total resistance)} = 1.1\text{V}$ .

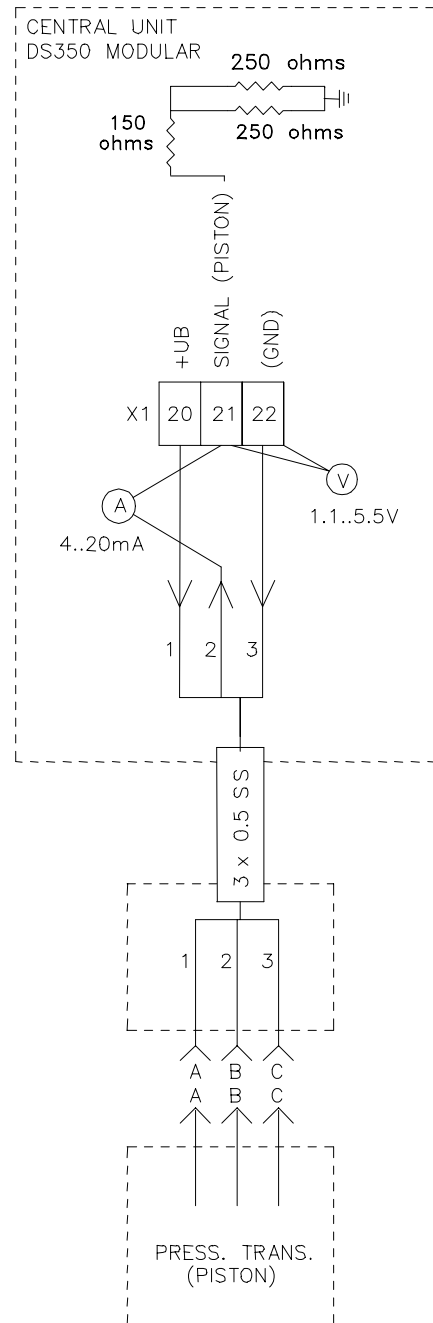
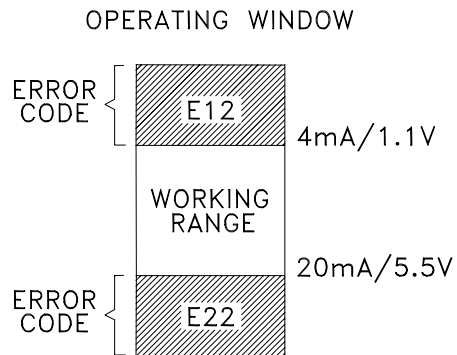

### 6.3 THEORY 3. OPERATION OF ROD SIDE LOAD SENSOR

#### Measuring current:

The ammeter (A) is used to measure current at the rod side input signal. Remove the wire from X1:24 terminal in the central unit and measure the current with the ammeter in series. The measurement should be between 4..20mA.

#### Measuring voltage:

The voltmeter (V) is used to measure voltage between pins X1:24 (rod side signal) and X1:25 (gnd) on the main board (024-352-300-001 / 9333103287). The resistors are there to show that at 4mA the voltage is 1.1V because current multiplied with resistance equals voltage; therefore, 4mA x 275 ohms (total resistance) = 1.1V.

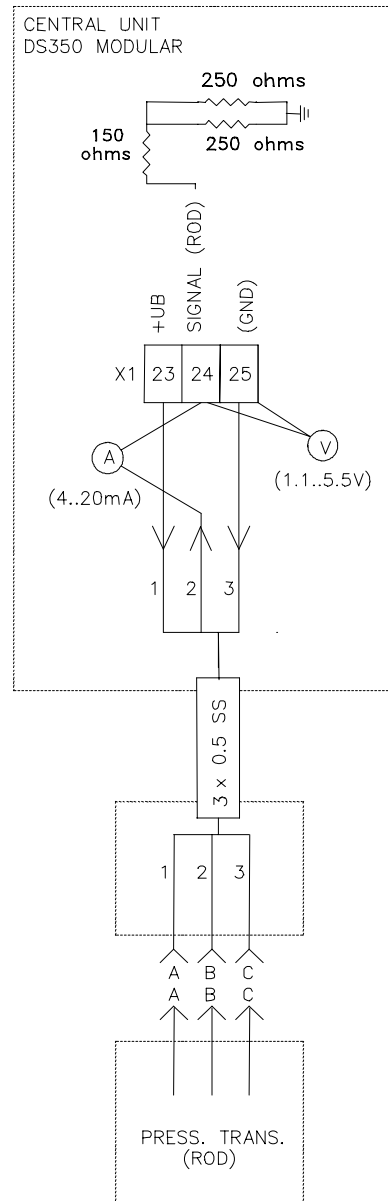
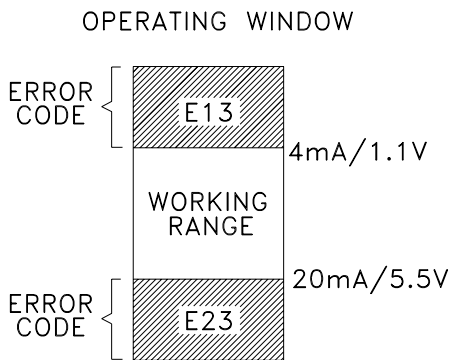

### 6.4 THEORY 4. OPERATION OF ANGLE SENSOR

#### Measuring current:

The ammeter (A) is used to measure current at the angle input signal. Remove the wire from X1:29 terminal in the central unit and measure the current with the ammeter in series. The measurement should be between 4..20mA.

#### Measuring voltage:

The voltmeter (V) is used to measure voltage between pins X1:29 (angle signal) and X1:28 (gnd) on the main board (024-352-300-001 / 9333103287). The resistors are there to show that at 4mA the voltage is 1.1V because current multiplied with resistance equals voltage; therefore, 4mA x 275 ohms (total resistance) = 1.1V.

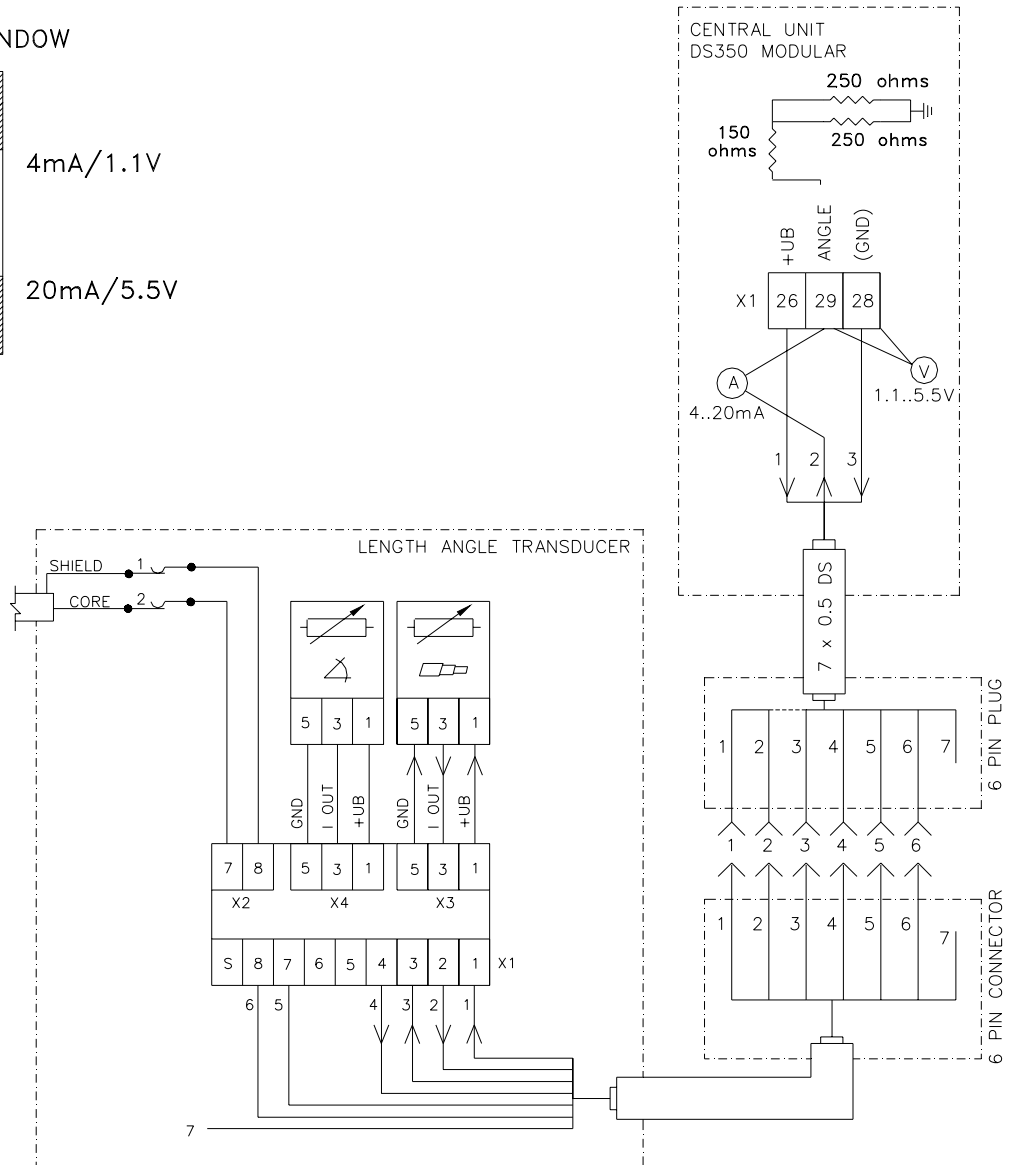
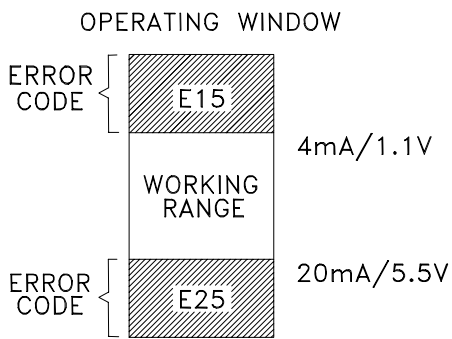

### 6.5 THEORY 5. OPERATION OF SLEW POTENTIOMETER SENSOR

#### Measuring current:

The ammeter (A) is used to measure current at the slew angle input signal. Remove the wire from X1:30 (slew signal 1) in the central unit and measure the current with the ammeter in series. And then measure current at terminal X1:34 (slew signal 2). The measurement should be between 4..20mA.

#### Measuring voltage:

The voltmeter (V) is used to measure voltage between pins X1:30 (slew signal 1) and X1:35 (gnd) and between pins X1:34 (slew signal 2) and X1:35 (gnd) on the main board (024-352-300-001 / 9333103287). The resistors are there to show that at 4mA the voltage is 1.1V because current multiplied with resistance equals voltage; therefore, 4mA x 275 ohms (total resistance) = 1.1V.

#### OPERATING WINDOW

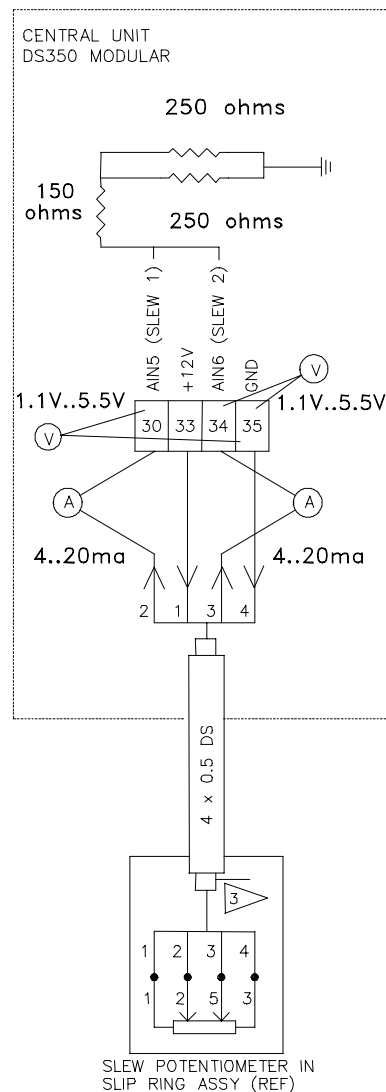
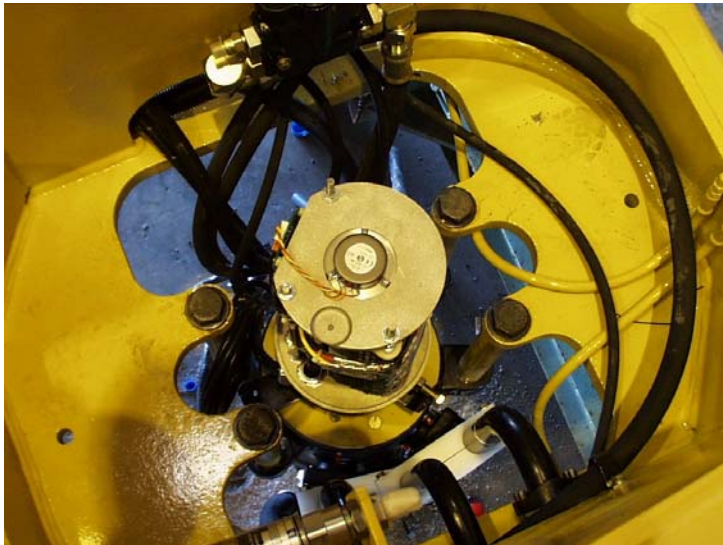
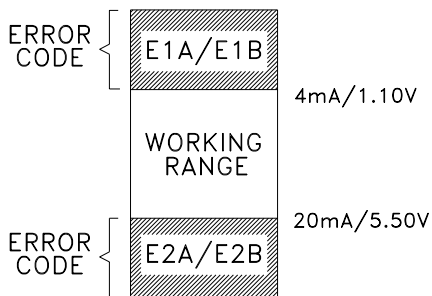

## 6.6 THEORY 6. OPERATION AXLE OSCILLATION OUTPUT

Axle oscillation is the ability of the crane axle suspension to articulate to the changing terrain. The digital output module sends power to energize a solenoid valve to allow axle oscillation. This current is sent when determined by the LMI software; the crane is in pick and carry mode, and within in a preset angle tolerance (e.g.  $\pm 12^\circ$ ) over the front of the crane. To troubleshoot this module, first, check if the on-board light is lit. This light indicates that the board is receiving both power and a proper ground. If the light is out, check the condition of the fuse, and board connection. To determine if a signal is present refer to the Measuring Voltage section.

### Measuring voltage:

The voltmeter is  $\text{V}$  used to measure voltage between pins X2/1:1 (digital output 1) and X2/1:3 (gnd) on digital output module (024-352-300-041 / 9333103291).

