



i4000

Multifunction indicator/range limiting device

Instruction Manual



Wylie Systems
(Rayco Technology Group)

1020 9th Avenue SW
Suite 124
Bessemer, AL
USA 35022

Tel: (205) 481-2080
Fax: (205) 481-2081



Rayco Electronic Systems
(Rayco Technology Group)

2440 Dalton Avenue
Ste-Foy, Qc
CANADA
G1P 3X1

Tel: (418) 266-6600
Fax: (418) 266-6610



Wylie Systems
(Rayco Technology Group)

Drury Lane
St-Leonards on Sea, East Sussex
ENGLAND
TN38 9BA

Tel: (+44) 1-424-421235
Fax: (+44) 1-424-433760



This manual provides users with the essential operating procedures for the good functioning of the machine and its intended use. We cannot stress strongly enough the need to use this system correctly. Make sure you have read and understood all the information included in this manual before operating the machine.

Since the manufacturer has no direct control over the machine's use, it is the user's and the personnel's responsibility to comply with good safety practices. All procedures dealt with in this manual are based on appropriate operating conditions which do not depart from the intended use of the system. It is strictly forbidden to alter or modify the equipment without written authorization from RaycoWylie Systems.

The i4000 system by RaycoWylie Systems (Multifunction indicator) is purely an aid to the operator. When the parameters are correctly set, the indicator warns the crane operator of a potential overload which could endanger the equipment or the goods, and cause injuries to the operator or the workers who are close to the crane and its load.

This system must not be used as a substitute for the operator's sound judgement while performing tasks with the lifting equipment. The operator is responsible for the safe operation of the lifting equipment. If the lifting equipment is not correctly configured, the system may not warn about possible damages due to an overload or other similar cause.

Before handling a crane equipped with a RaycoWylie multifunction indicator, the operator must read carefully this manual and the operations manual provided by the crane manufacturer. He must also be aware of all the national, state, or local safety standards and regulations applicable to his work. The adequate functioning of the system requires a daily inspection.

Any apparent failure or damage must be immediately reported to the responsible person in charge before operating the crane.

Since the personnel's safety and the appropriate use of the machinery are a priority, different symbols are used in this manual to highlight important points.

The following definitions indicate the level of risk each symbol represents. Each time you see one of these symbols in this manual, the operator's safety or the machinery's integrity are concerned.

Please take your time to read and understand these definitions!



DANGER: INDICATES A POTENTIALLY DANGEROUS SITUATION WHICH, IF NOT AVOIDED, COULD RESULT IN A PERSON'S DEATH OR IN SIGNIFICANT DAMAGE TO THE MACHINERY.



ATTENTION: INDICATES A POTENTIALLY DANGEROUS SITUATION WHICH, IF NOT AVOIDED, COULD RESULT IN MINOR OR MODERATE DAMAGES. IT CAN BE USED TO WARN ABOUT UNSAFE PRACTICES.



IMPORTANT: INDICATES A SITUATION WHICH COULD DAMAGE THE MACHINERY.



NOTE: PROVIDES INFORMATION WHICH CAN BE OF SPECIAL INTEREST.

CONTENTS

Warning	page 5
1- GENERAL DESCRIPTION OF THE SYSTEM	page 13
1.1 Introduction	page 13
1.2 Operator skill	page 13
1.3 Usefulness of the i4000 system	page 13
1.4 Description of the i4000 system	page 14
1.4.1 Audible alarm	page 15
1.4.2 Visual alarm	page 15
1.5 Location and description of typical components	page 16
1.6 Overall scheme	page 17
1.7 Technical information	page 18
2- DETAILED DESCRIPTION OF THE DISPLAY UNIT	page 19
2.1 Navigating the normal mode of operation	page 19
2.2 Indicator tab	page 20
2.3 Load tab	page 21
2.4 Range limiting device tab	page 22
2.5 Tools tab	page 22
2.6 Overview of the display unit	page 23
2.7 Description of operation keys	page 24
2.8 Warning lights and messages	page 25
2.8.1 Overload warnings	page 26
2.8.2 Anti-two block and rope limit indicators	page 27
3- INSTALLATION AND CALIBRATION	page 29
4- OPERATING INSTRUCTIONS	page 31
4.1 Safety recommendations	page 31
4.2 Residual risks	page 32
4.3 Power-up	page 33

CONTENTS

4.4	System in CONFIGURATION mode	page 34
4.4.1	Access the Configuration menu	page 34
4.4.2	Selecting the Measuring unit	page 35
4.4.3	Selecting the Language	page 36
4.4.4	Selecting the Light intensity	page 37
4.4.5	Adjust system time and date	page 38
4.5	System in LIFTING mode	page 39
4.5.1	Selecting crane configuration	page 39
4.5.2	Selecting the lifting hoist	page 40
4.5.3	Adjusting the hoist's parameters	page 41
4.5.3.1	Maximum load allowed	page 41
4.5.3.2	Number of parts of line	page 42
4.5.4	Defining or removing the zero setting mode (tare)	page 43
4.5.5	Bypassing a lockout	page 44
4.6	System in ABSOLUTE LIMITING mode	page 45
4.6.1	Accessing the absolute limiting adjustment mode	page 46
4.6.2	Activating or deactivating an absolute limit	page 46
4.6.3	Adjusting an absolute limit value	page 47
4.7	RANGE LIMITING mode warnings	page 48
4.7.1	Range limiting option	page 49
4.7.2	Accessing the range limiting adjustment menu	page 49
4.7.3	Height limit	page 50
4.7.4	Free zone	page 51
4.7.5	Variable height limit	page 52
4.7.6	Variable radius limit	page 54

CONTENTS

5- DIAGNOSTIC AND MAINTENANCE	page 57
5.1 Diagnostic menu	page 57
5.2 Angle and length sensor	page 59
5.3 Load sensor	page 60
5.4 Detected addresses	page 60
5.5 Error messages	page 61
5.5.1 Internal peripherals	page 61
5.5.2 External peripherals	page 62
6- INSPECTION AND MAINTENANCE	page 65
6.1 Frequent inspections	page 65
6.2 Periodic inspections	page 65
6.3 Checking the displayed load	page 66
6.4 Maintenance	page 67
6.5 Maintenance procedure	page 68
6.6 Adjustments and repairs	page 69

-1-

General description of the system

1.1 Introduction

This manual contains information regarding the operation, troubleshooting, and maintenance procedures of the i4000 system. Please make sure you respect the safety rules currently in force in the country where you are using the i4000 system, in order to reduce the risk of injuries or of damages to the machinery. Please consider each safety directive mentioned in this manual when using the i4000 system. This manual will help qualified personnel use the system and perform its maintenance.

1.2 Operator skill

The i4000 system shall be operated only by personnel without limitations in the physical abilities of the upper limbs and no visual or hearing impairment, who have completed all operator trainee qualification requirements and have read and fully understood the instructions in this manual. Operator requirements shall include: demonstrating the ability to read, write and comprehend and use arithmetic and read and understand the load / capacity charts in the language of the crane manufacturer's operating instruction materials. Maintenance of the system is intended only for fully qualified and trained personnel for this task.

1.3 Usefulness of the i4000 system

The i4000 system is designed to aid the crane operator by indicating the machine's parameters which require special attention. If it is correctly calibrated, configured and operated, the i4000 system should work to prevent the crane from lifting a load in excess of the nominal load authorised for the crane or the lifting rope.

1.4 Description of the i4000 system

The i4000 « Multifunction indicator» is a computerized system designed to provide the operator with the necessary information to operate the crane safely, and within the nominal load limits authorized by the crane manufacturer.

The indicator works by indicating to the operator the load applied to the crane, so that he may compare this load with the nominal load authorized for each lifting position.

The system's display unit provides the operator continuous information regarding the crane's current load. It also warns the operator whenever he approaches or exceeds the maximum load limit.

The system includes sensors installed on the crane that measure or verify:

- the weight on the hook,
- the boom angle (optional),
- the boom length (optional),
- the position of the A2B block (optional).



When the above options are included, the system uses the information provided by the sensors to calculate the operational radius, allowing the operator to assess the crane's current capacity, and to verify the overload conditions.

A rotation sensor (optional) can also be installed to measure the boom position within 360 degrees and provide the operator with additional information.

The system display is located inside the cabin, close to the operator controls for easy access to the information. All sensors are connected through a CAN bus network. The allowed capacity is assessed by the operator. With the measures provided by the i4000 system, he will be able to identify the allowed load in the manufacturer's chart.

The actual load is expressed as a percentage of the allowed capacity. This becomes the nominal load or 'safe working load' - % SWL. If this percentage exceeds a predetermined value, the alarms and safety functions will be activated.

The crane's parameters and calibration data will be saved in a separate non-volatile memory.

1.4.1 Audible alarm



An intermittent audible alarm within the display unit warns the crane operator that an intervention is necessary before the load reaches its nominal value. The default threshold for the approaching alarm is 90% of the nominal capacity. The overload alarm is activated continuously when 100% of the nominal capacity is reached or exceeded. The crane operator will also be warned by the internal audible alarm when approaching or reaching a limit that he had already defined.



The approach and overload alarm settings can be modified according to the user's preferences.



If you are wearing hearing protectors or headphones during lifting operations, make sure they do not impair your ability to hear the sound alarms of the i4000 system.

1.4.2 Visual alarm

The i4000 system display has been equipped with a 3-colour warning light to alert the operator and to indicate a specific action.

The flashing yellow light turns on together with the sound alarm when the load reaches the approach alarm's threshold, that is, 90% of the nominal capacity.

The light turns red when 100% of the nominal capacity is reached or exceeded.

This light is green under normal operating conditions.



1.5 Location and description of typical components



1. **The i4000 display unit:** It is also the central unit of the i4000 system. Its main characteristics are the bus CAN communications interface and the liquid-crystal graphic display.
2. **The central input/output interface:** This relay interface module is connected to individual external input and output devices controlled by the i4000 system (optional).
3. **Load sensor:** A load sensor is used in order to calculate the load on the hook. It is generally integrated into a dynamometer installed on the lifting rope.
4. **Cable reel with angle and length sensor:** An angle sensor is used in order to measure the boom angle. A potentiometer is used for measuring the boom extension (optional).
5. **Limit switch (A2B)** The limit switch helps to prevent the pulley block from colliding with the boom head pulley (optional).
6. **Wind speed sensors (anemometer)** They show the wind speed on the display unit screen (optional).

1.6 Overall scheme

i4000 Bloc Diagram

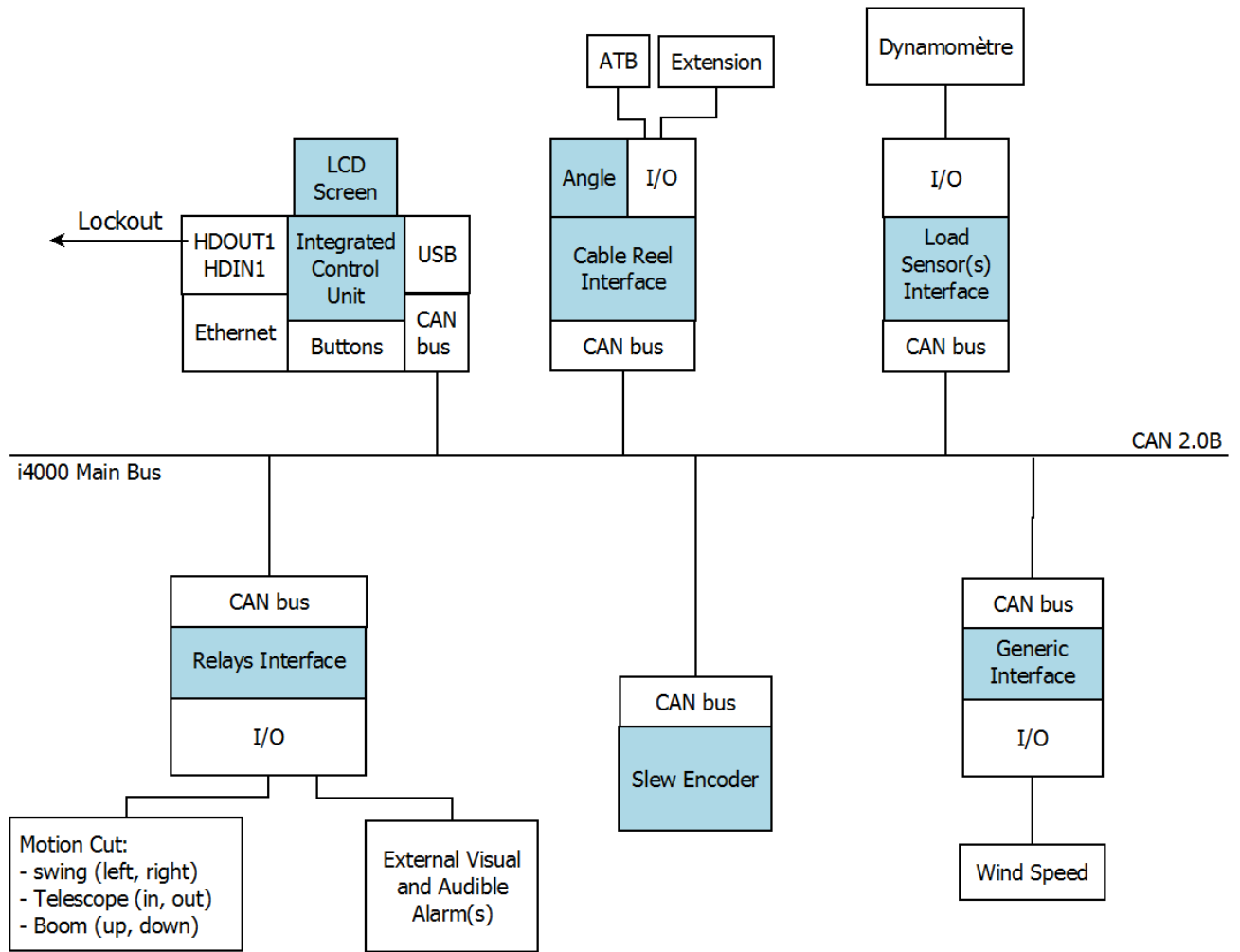

1.7 Technical information

Accuracy:	In accordance with SAE J159
Operating temperature:	-20°C to +60°C
Power supply:	9-32 VDC (maximum power supply)
Display unit dimensions:	3.5" Crystal liquid screen (320 x 240)
Display unit protection:	IP67

Bus CAN interface/ sensors:	Default quantity	Maximum quantity
-Load or pressure sensors	1	2
-Angle or length sensors	1	1
- Relay output	1	1
- Rotation sensor	1	1
- Possibility of additional sensors	YES	
- Radio Module	0	1

-2-

Detailed description of the display unit

2.1 Navigating the normal mode of operation

The normal mode of operation of the i4000 system is organized into four separate screens. We call it “tabs”. Use the left or right arrow keys to navigate in these tabs.

There are:

- 1) the indicator tab
- 2) the load tab
- 3) the range limiting tab
- 4) the tools tab

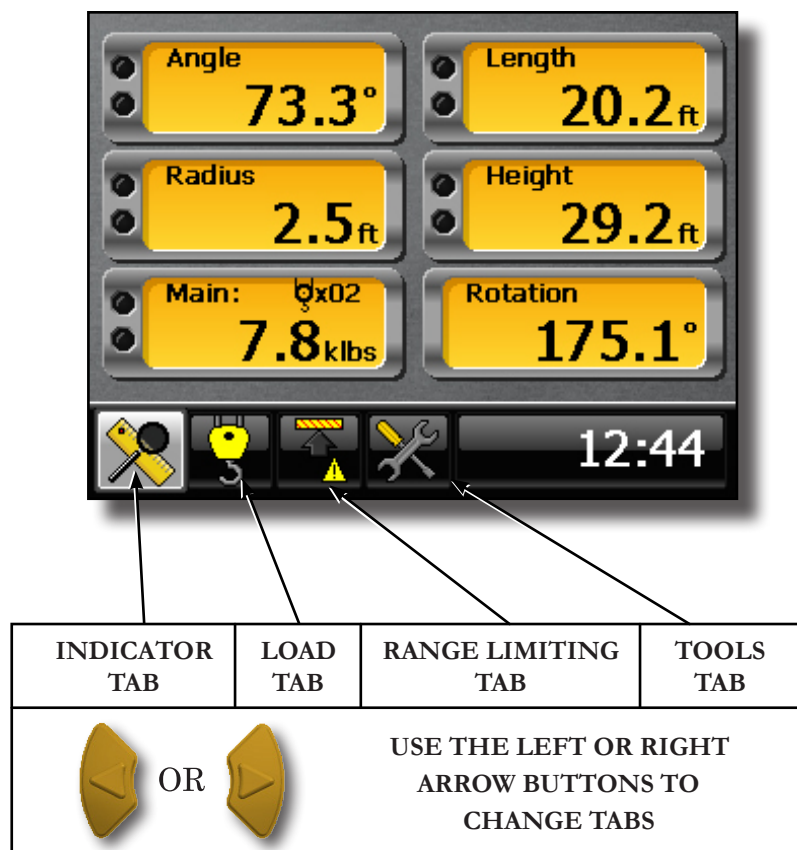

2.2 Indicator tab

It allows the display of multiple sensors, providing a good overview of the crane during operation.

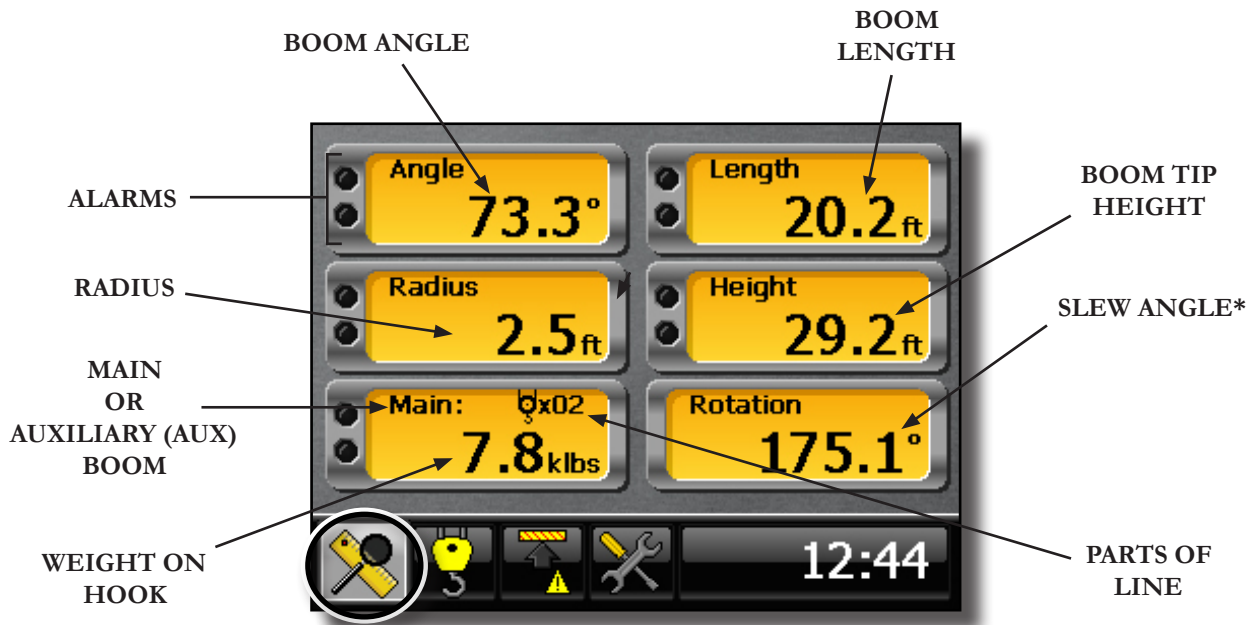

The parameter indicating the boom tip height should only be used as a guide and NOT as an indicator of whether the crane may pass or not underneath a structure whose exact height is known.



Some mini-dials are only displayed if the corresponding sensor is installed.

2.3 Load tab

For a more detailed display of everything concerning the load to be lifted. The hoist, the number of strands and the maximum capacity are adjusted under this tab.

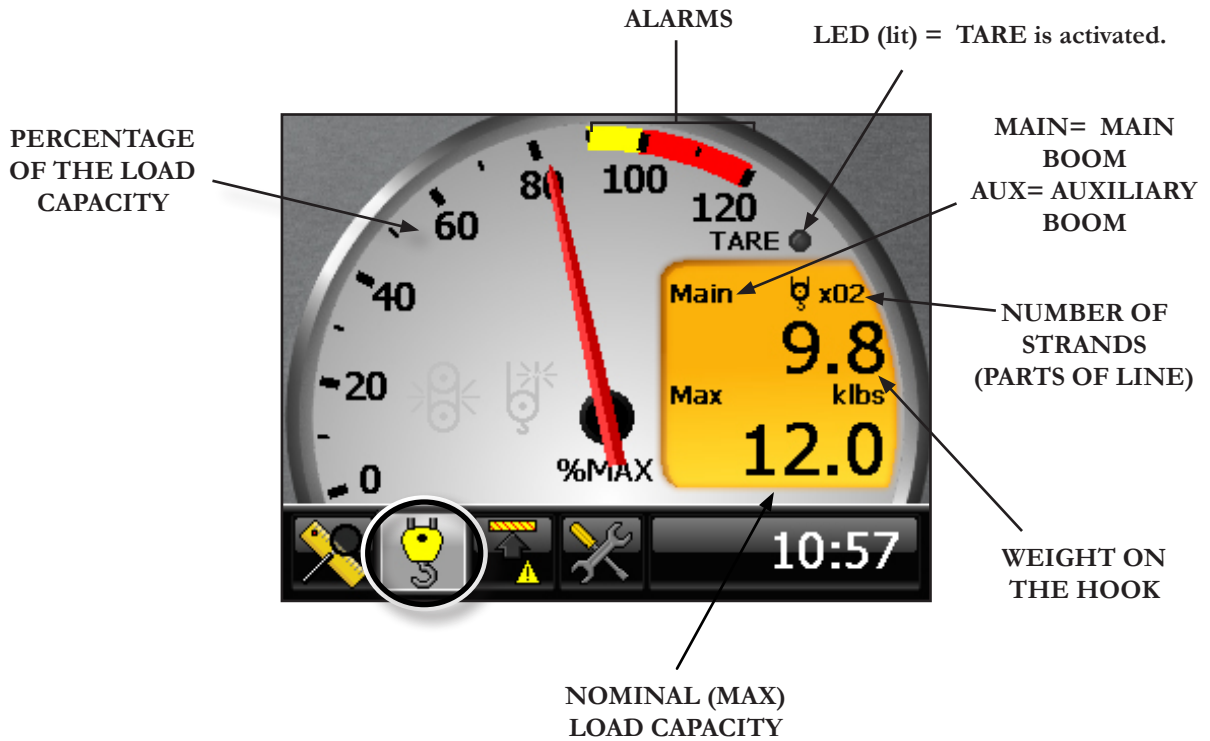

The (Load) tab will only be shown if a load interface is activated.

2.4 Range limiting tab

For viewing all the information about the programmed limit. Limits are removed or added under this tab.

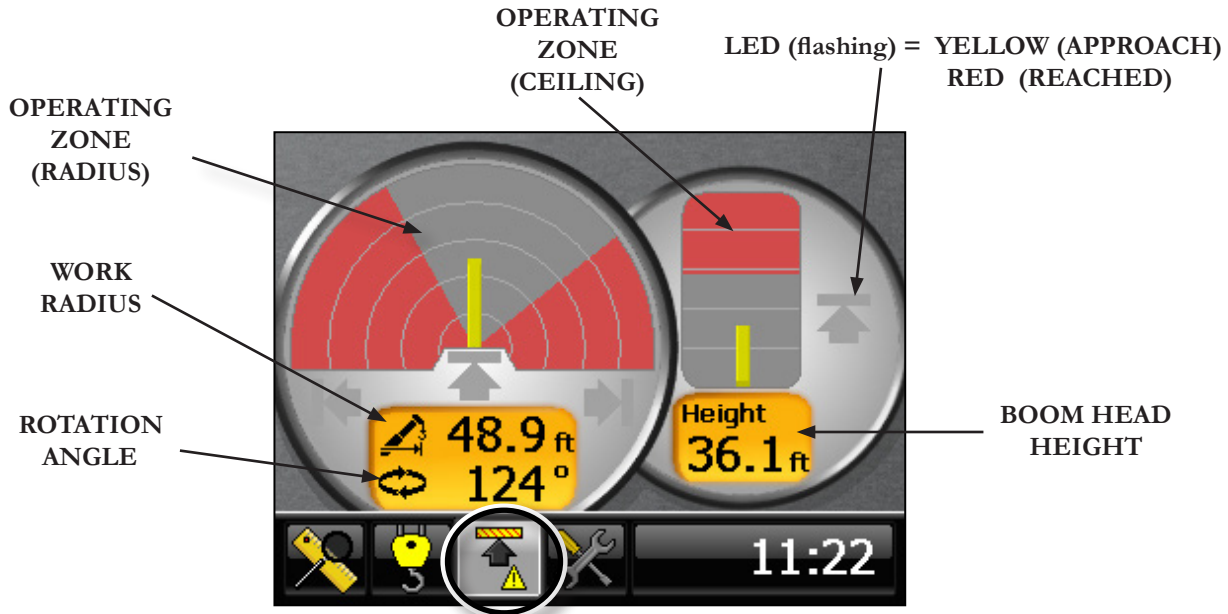

The range limiting tab will only be shown if a rotation interface is activated.



The parameter indicating the boom tip height should only be used as a guide and NOT as an indicator of whether the crane may pass or not underneath a structure whose exact height is known.

2.5 Tools tab

Under the tools tab you will find among others: the diagnostic mode, the error mode, the calibration mode and the day / night display mode.

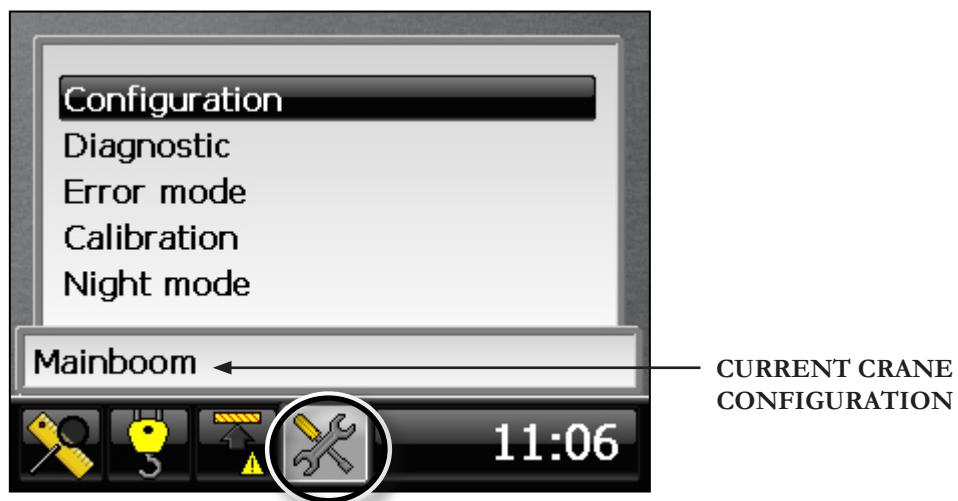

2.6 Overview of the display unit

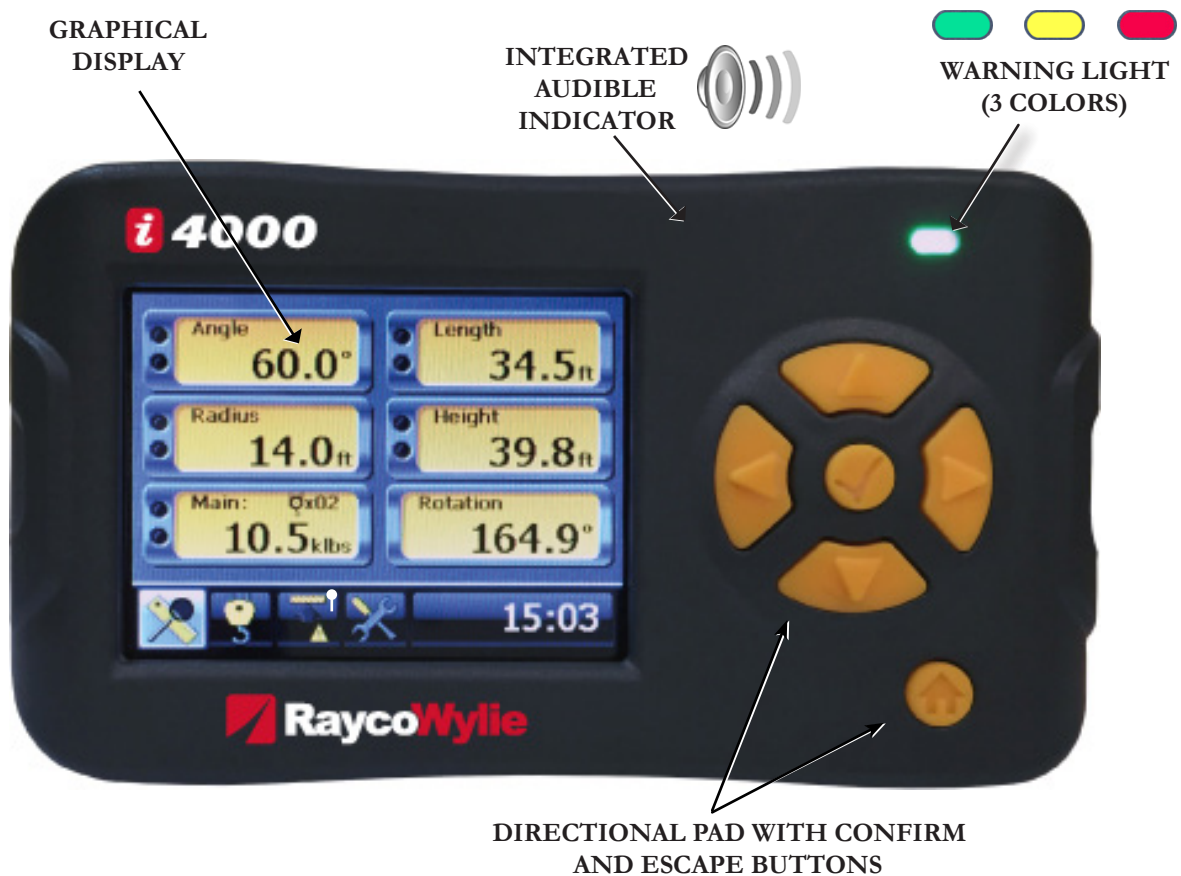

WARNING LIGHT

Under normal working conditions, the light is green. The light turns yellow to indicate the approach to a preset operating limit. The light turns red to warn the operator of any abnormality.

2.7 Description of operation keys



LEFT KEY

Press this key to scroll left through the tabs of the main menu or, in Edit mode, to return to the previous digit of a configurable value.



RIGHT KEY

Press this key to scroll right through the tabs of the main menu or, in editing mode, to move on to the next digit of a configurable value.



UP KEY

Press this key to scroll up through the options of the main menu or, in Edit mode, to increase a configurable value.



DOWN KEY

Press this key to scroll down through the tabs of the main menu or, in Edit mode, to decrease a configurable value.



CONFIRM KEY

Press this key to confirm your choice in any menu and to accept new values in the system.



ESCAPE KEY

Press this key to leave a menu or settings window, and to return to the previous screen without saving the changes. Press several times to return to the main menu.

2.8 Warning lights and messages

ABSOLUTE LIMITING DEVICE

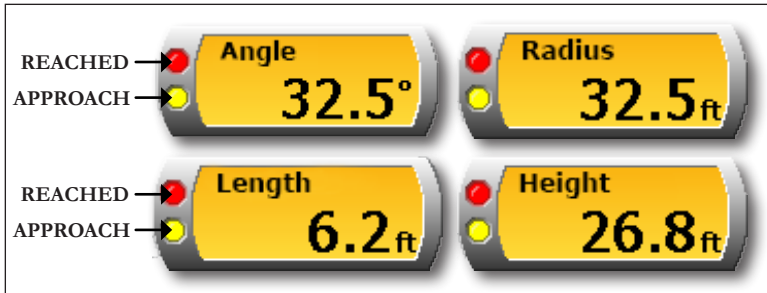

WARNING LIGHT

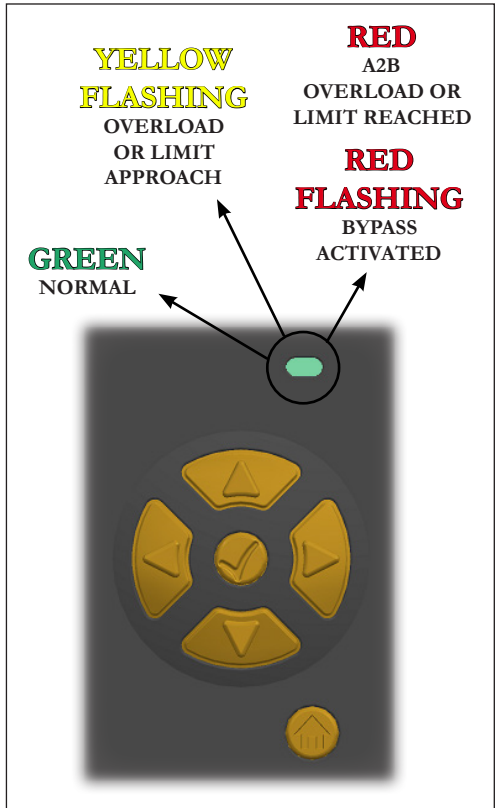

RANGE LIMITING DEVICE

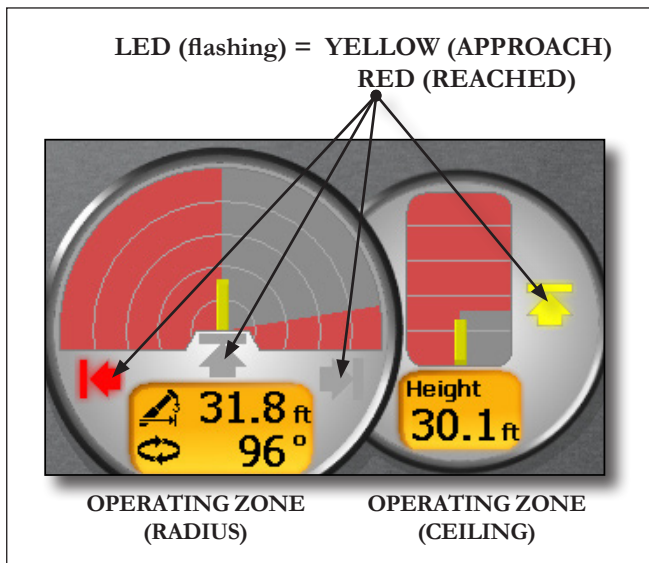

LOAD TAB INDICATORS

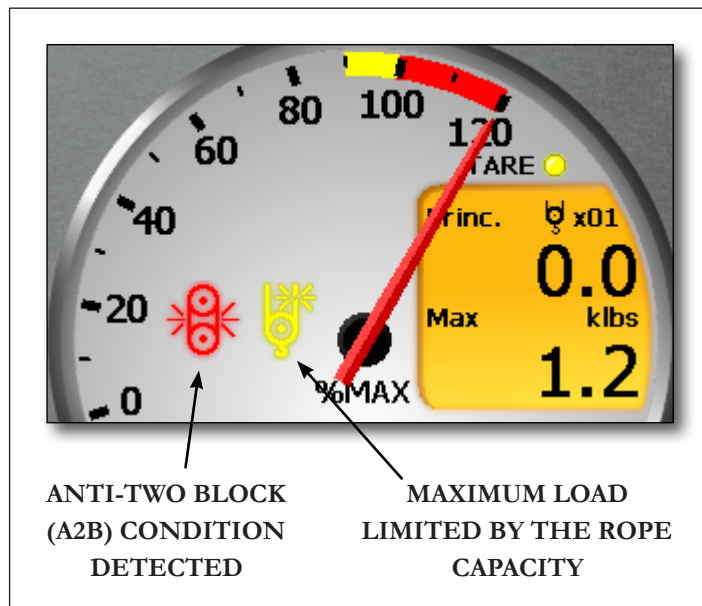

2.8.1 Overload warnings

The yellow APPROACH signal lights up when the load on the hook reaches between 90 % and 99.9 % of the load capacity (adjustable value). The yellow warning light flashes, accompanied by an intermittent audible alarm.

INDICATOR TAB:



Flashing yellow

LOAD TAB:

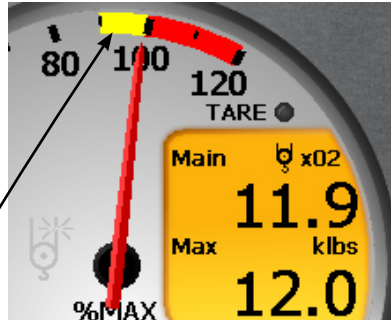

Needle is in the yellow area

WARNING LIGHT:



Flashing yellow



Handle with caution!
The crane is working near its nominal load limit.

The red REACHED signal lights up when the load on the hook is equal or more than 100 % of the nominal capacity (adjustable value). The warning light turns red. The audible alarm sounds continuously.

INDICATOR TAB:



Flashing red

LOAD TAB:

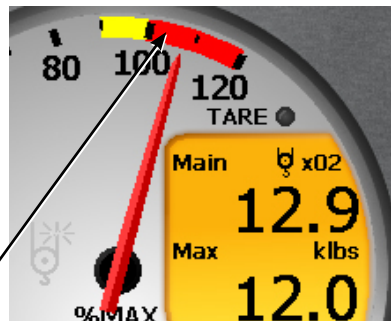

Needle is in the red area

WARNING LIGHT:



Solid red



The crane's nominal capacity has been reached or exceeded.

**Load indicator
Overload**

A warning message will be displayed in the range limiting tab in order to inform the operator that a load limit has been reached.

2.8.2 Anti-two block and rope limit indicators

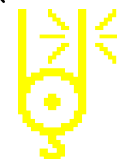
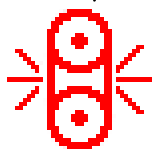
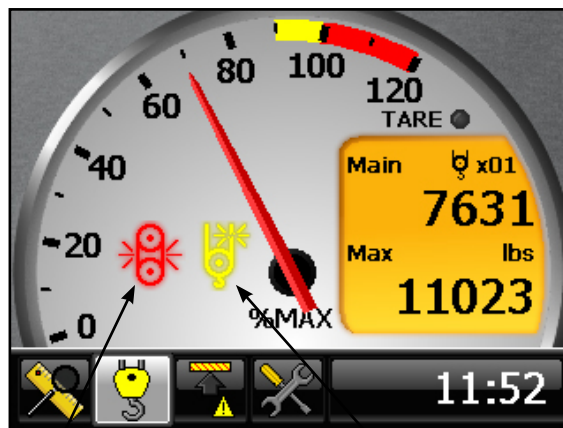

The anti-two block (A2B) indicator appears on the screen of the i4000 when the hook pulley is near the boom head pulley. This may block the hoist function and the booming down depending on crane model and/or on the options fitted on the machine.

The rope's capacity limit indicator appears on the screen of the i4000 system to indicate that the allowed nominal load is limited by the rope's safe operation limit. Increase the number of strands (parts of line) between the head pulley and the pulley block, and change the number of strands on the i4000 system to turn off this indicator and thus increase the crane's nominal capacity.

**Load indicator
ATB detected**

A warning message will be displayed on the other tabs (INDICATOR and RANGE LIMITING DEVICE) in order to inform the operator that an ATB has been detected.

-3-

Installation and Calibration

A qualified technician should perform the installation of the i4000 system.

Moreover, the system must be calibrated by a RaycoWylie technician.

The RaycoWylie technician will perform a complete and precise verification of the system before starting the calibration.



A bad calibration of the system can cause an overload which could damage the machine (breaking the structure or tilting), causing serious injuries and even death. You must always have a RaycoWylie technician calibrate your system.



Manuals concerning the installation and calibration are available upon request from RaycoWylie. Please note that the calibration and installation instructions have been intentionally left out of this manual.

-4-

Operating Instructions

4.1 Safety recommendations:

Please make sure you respect the safety rules currently in force in the country where you are using the i4000 system, in order to reduce the risk of injuries or of damages to the machinery. Please read the following safety instructions before trying to operate the system.

1. The machine operator must configure the crane and the work environment correctly. A bad configuration could threaten the reliability of the system and cause dangerous situations such as an overload.
2. The i4000 system is purely an aid to the operator. It is the operator's responsibility to handle the crane with caution, since the i4000 system will not necessarily prevent damages to the machine due to an overload or other causes.
3. The proper functioning of the equipment depends on a daily inspection and on compliance with this manual's operating instructions.
4. The crane should always be operated smoothly and at a safe speed.
5. In order to have an adequate work radius, the system must be correctly configured. A wrong configuration may generate a wrong calculation of the radius, which the operator will use to assess the maximum load allowed for a given lifting operation. This may result in damages to or toppling of the machine.
6. The operator must verify the crane's parameters and the number of strands used for each available hoist each time he gets in the machine or the crane is configured.



Note: the configuration of each hoist is stored in the memory. When the main hoist is replaced by the auxiliary hoist, the configuration and the number of strands **will change as a result**.

4.2 Residual risks

Even if all safety rules are applied and safety devices are installed, certain residual risks are inevitable. For example:



The system will not warn about a malfunction of relay outputs, which could prevent the locking of commands in case of an overload. This may increase the risk of the machine breaking or tilting, thus causing injuries and even death.



The system does not indicate the presence of electric wires in the crane's work zone. The machine may therefore work close to and come in contact with undetected electric wires, which may cause serious injuries or even death.



The system does not indicate if the stabilizers have completely come out. This may increase the risk of the machine breaking or tilting, thus causing injuries and even death.



The system does not indicate the crane's level. This may increase the risk of the machine breaking or tilting, thus causing injuries and even death.



The system does not indicate if the soil is stable. This may increase the risk of the machine breaking or tilting, thus causing injuries and even death.

4.3 Power-up

When the i4000 system is turned on, it runs a self-diagnostic during which it verifies the communication between the CAN bus and the installed sensors. It then loads in its usage memory (RAM) the information saved in its non-volatile (ROM) memory. During this stage, the RaycoWylie logo appears on screen. When the test is completed and the live memory is ready, the warning light turns green and the i4000 system is ready to be used.

If there is at least one jib activated on the i4000, the system will present the current configuration. The crane operator must now confirm the configuration proposed by the system (by selecting Yes), or choose another configuration (by selecting No).

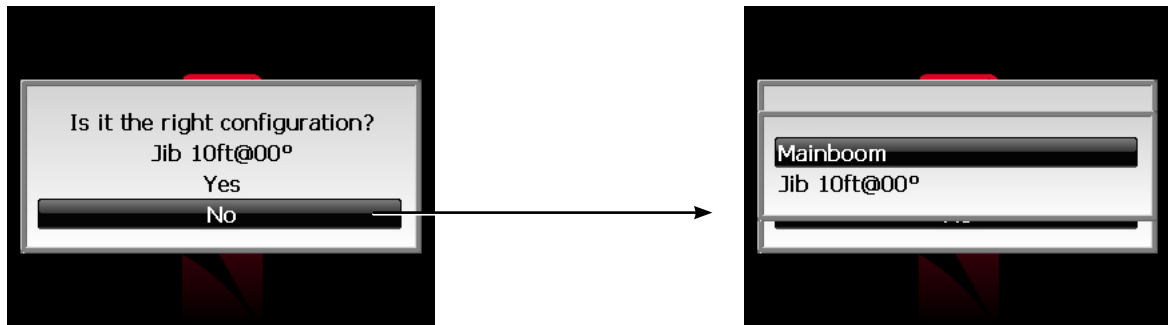

Once he has chosen a configuration, the i4000 system switches to its normal operating mode.

If a limit has been set up and it has not been erased during the last session, the i4000 will then display the following screen:

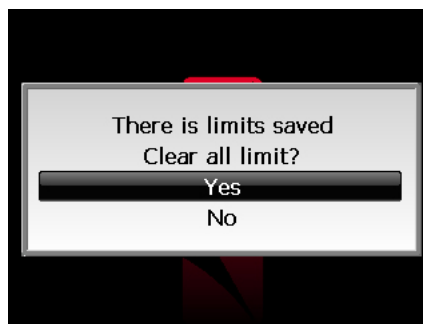

This tells the operator that a limit has been saved already and asks if it is still valid. This screen will not appear if no limit is programmed into the system.

4.4 System in configuration mode

This allows the operator to personalize his system. Namely, the display language, the measuring unit, the light intensity of the graphic display, the date and time.

4.4.1 Access the Configuration menu

You need to be in operating mode (main screen). The lower part of the screen should look like this:



The screen may vary depending on the sensors which are activated. E.g., if a rotation sensor is installed, the 'Range limiting device' will be present.



1. Navigate to the Tools tab with the LEFT or RIGHT keys.



2. Press the **'ENTER'** key to access the configuration options.



Now you can choose the option you wish to configure.

4.4.2 Selecting the measuring unit

This option allows the operator to choose the measuring unit used in the display. He can choose either METRIC (m/kg, m/te) or IMPERIAL (ft/lbs, ft/Tons, ft/long Tons, ft/klbs).

1. Access the Configuration menu (see section 4.4.1).



2. Scroll vertically to the 'Units' menu with the 'UP/DOWN' keys.



3. Press 'ENTER' to change the unit.



4. Choose the desired unit using the 'UP/DOWN' keys.



5. Press 'ENTER' again to save the unit. Or press the 'ESCAPE' key to quit without saving the changes.

4.4.3 Selecting the language

This option allows the operator to choose the language in which all the texts in the system will be displayed. The default language is English.

1. Access the Configuration menu (see section 4.4.1).



2. Scroll vertically to the 'Language' menu with the 'UP/DOWN' keys.

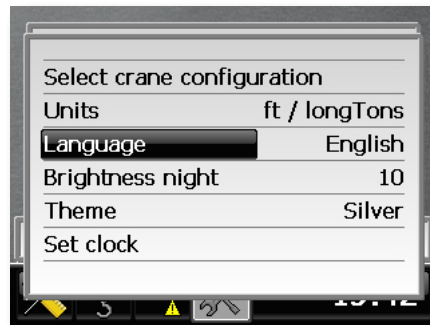

3. Press 'ENTER' again to change the language.

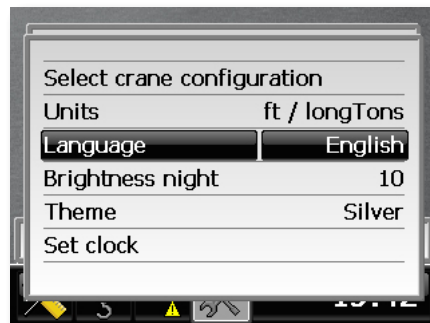

4. Choose the desired language using the 'UP/DOWN' keys.



5. Press 'ENTER' again to save the language. Or press the 'ESCAPE' key to quit without saving the changes.

4.4.4 Selecting the light intensity

This option allow the operator to adjust the light intensity of the graphic display in NIGHT MODE. The values range from 5 to 100. 5 is the lowest intensity and 100 is the maximum intensity.

1. Access the Configuration menu (see section 4.4.1).



2. Scroll vertically to the 'Brightness night' menu with the 'UP/DOWN' keys.

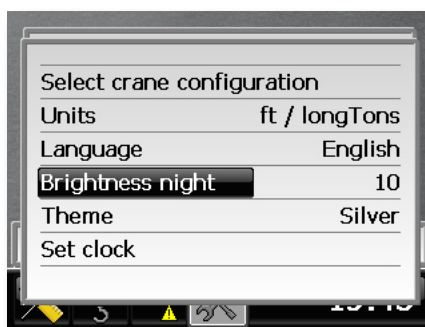

3. Press 'ENTER' to change the 3 digits.



4. Change the first digit by entering your desired value, using the 'UP/DOWN' keys.

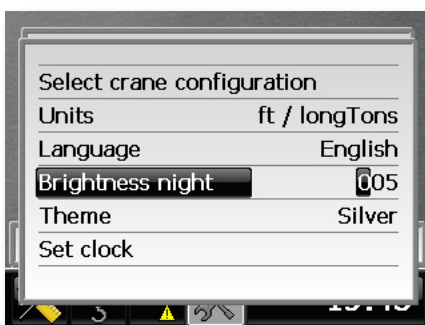

5. Then press the 'ENTER' key again to move to the following digit. Repeat steps 3 and 4 for the following digits. After entering the last digit, press 'ENTER' to save the value.



At any time, press the 'ESCAPE' key to go back without saving changes.

4.4.5 Adjust system date and time

This option allows the operator to modify the date and time of the system. It is important to enter the right date and time since the event logger will use them.

1. Access the Configuration menu (see section 4.4.1).



2. Scroll vertically to the 'Set clock' menu with the 'UP/DOWN' keys.

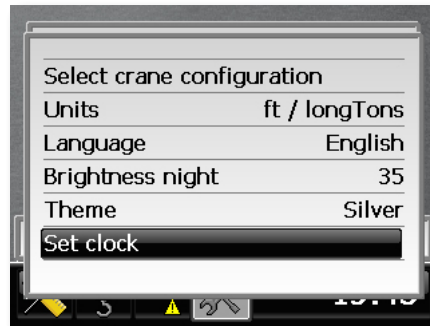

3. Press 'ENTER' again to access the menu. The following menu will appear:

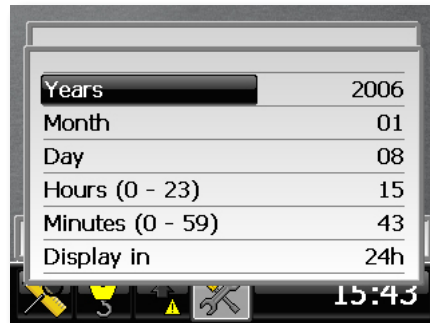

4. Scroll vertically to the item you wish to change, using the 'UP/DOWN' keys.



5. Press 'ENTER' to make the change. In the example, "Year" has been selected.



6. Change the first digit by entering your desired value, using the 'UP/DOWN' keys. Next, press 'ENTER' to move to the second digit. Repeat step 5 for the following digits. After entering the last digit, press 'ENTER' to save the value.

4.5 System in lifting mode

4.5.1 Selecting crane configuration



This allows the operator to choose the type of attachments mounted on the crane. This is very important since the calculation of the radius depends on it. In turn, the maximum load lifted by the operator will depend on the radius.



An error may result in an overload of the crane and the risk of the machine breaking or tilting, thus causing serious injuries or even death. You should never set up a configuration of which you are not completely certain. Better ask for assistance from a qualified technician.



Navigate to the Tools tab with the LEFT/RIGHT keys to view the current crane configuration on the lower part of the screen.

CURRENT CRANE CONFIGURATION

TOOLS TAB

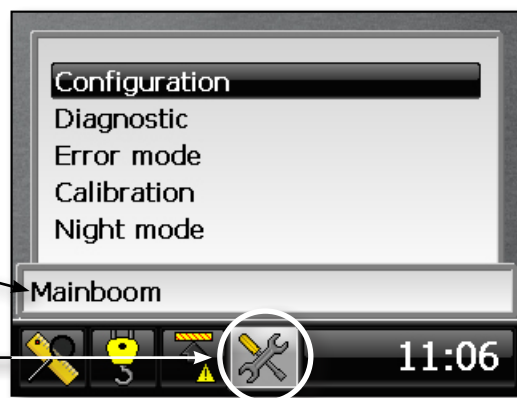

1. To change the configuration, go to the item 'Configuration' and press 'ENTER'.



2. Scroll vertically to the 'Select crane configuration' menu with the 'UP/DOWN' keys.



3. Press 'ENTER' to access the menu.

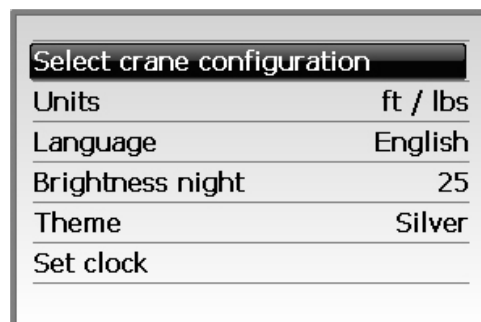

Continued on next page...

4.5.1 Selecting crane configuration (cont.)



- Use the 'UP/DOWN' keys to choose the configuration which corresponds to the current crane configuration.

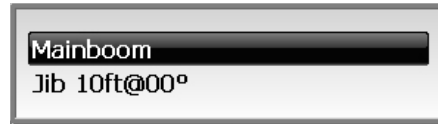

- Press 'ENTER' to accept the new configuration. Or press the 'ESCAPE' key to quit without saving the changes.

4.5.2 Selecting the lifting hoist



- In the main mode (operating mode), select the Load tab using the 'LEFT/RIGHT' keys.



- Press 'ENTER' to view the 'lifting hoist parameters' menu.



- Now you can select the hoist you will use for the lifting operation. Press 'ENTER' to edit the hoist.



- Use the 'UP/DOWN' keys to choose the desired hoist.



- Press 'ENTER' again to confirm your selection.



A maximum of 2 hoists are available. When a 2nd load interface is activated during calibration, the Auxiliary hoist will appear automatically in the list of hoists to edit.

4.5.3 Adjusting the hoist's parameters

Once the hoist to be used has been selected (either the main hoist or the auxiliary hoist), you can change its parameters. These are: the maximum load allowed (maximum capacity authorized by the crane manufacturer) and the number of parts of line.

4.5.3.1 Maximum load allowed

The lifted load is always compared to this value in order to warn the operator when he approaches or reaches an overload and to apply a motion cut if necessary. Use the crane's manufacturer capacity chart to find the maximum load that can be lifted for your current configuration.



1. In the main mode (operating mode), select the Load tab using the 'LEFT/RIGHT' keys.



2. Press 'ENTER' to view the 'lifting hoist parameters' menu.



3. Scroll to the Max load line using the 'UP/DOWN' keys.



4. Press 'ENTER' to edit the value.



5. Change the first digit by entering your desired value, using the 'UP/DOWN' keys.



6. Press 'ENTER' again to move to the second digit.

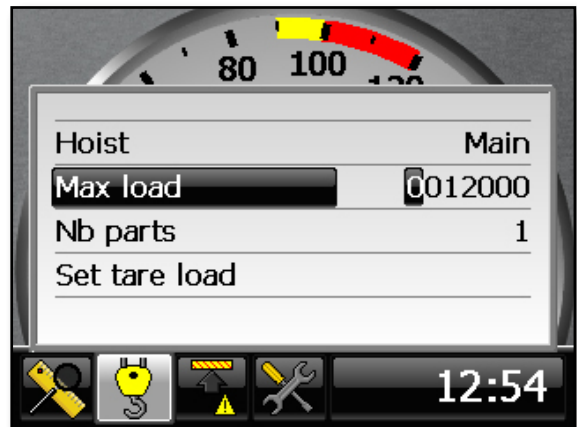

Repeat steps 5 and 6 for the following digits. After entering the last digit, press 'ENTER' to save the value.



Press the 'LEFT' key to go back to the previous digit. Press the 'RIGHT' key to go to the next digit.

At any time, press the 'ESCAPE' key to go back without saving changes.

4.5.3.2 Number of parts of line

The number of parts of line is used for load calculation and it helps to assess the allowed lifting limit of the rope. A indicator will lights up if the maximum load is limited by the rope's capacity.

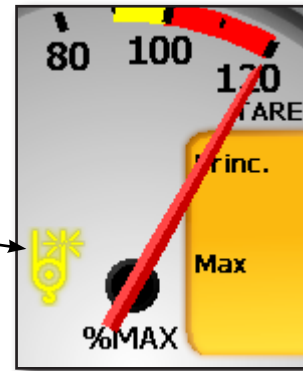

To change the number of parts of line, follow these steps:



1. In the main mode (operating mode), select the Load tab using the 'LEFT/RIGHT' keys.



2. Press 'ENTER' to view the 'lifting hoist parameters' menu.



3. Scroll to the 'Nb parts' line using the 'UP/DOWN' keys.



4. Press 'ENTER' to edit the value.



5. Modify the desired value using the 'UP/DOWN' keys.



6. Press 'ENTER' again to save the value.

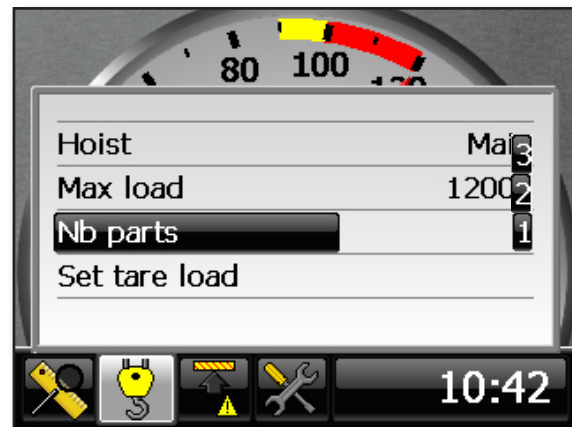

Each hoist (Main and Auxiliary) has its own 'maximum permitted load (Max load) and its own number of parts of line (Nb parts).

4.5.4 Defining or removing the zero setting mode (Tare)

Select the tare mode option to display the actual load on hook during a lifting operation. This mode is used to remove the weight of the block, hook and hoisting rope. This way it only shows on the screen the weight of the lifted load.

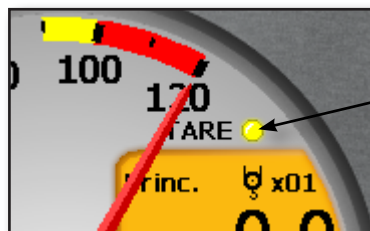

A YELLOW LIGHT INDICATES THAT THE TARE IS ACTIVATED (SOME WEIGHT HAVE BEEN REMOVED FROM THE CALCULATED LOAD)

To zero, do the following:



1. In the main mode (operating mode), select the Load tab using the 'LEFT/RIGHT' keys.



2. Press 'ENTER' to view the 'lifting hoist parameters' menu.



3. Scroll to the 'Set tare load' line using the 'UP/DOWN' keys.



4. Press 'ENTER' to activate the zero setting function. The line will then change to 'Clear tare load'.
5. Repeat these steps to cancel the Zero setting (remove tare).



To apply the 'Tare Load', the load must be higher than 0. Otherwise, nothing happens.

4.5.5 Bypassing a lockout



Be Careful! The i4000 does not support the rigging mode. In this situation, the crane is not entirely protected by the i4000, and it is therefore absolutely indispensable to comply with the manufacturer's recommendations on how to lift the pulley block, use the stabilizers, and perform a rotation.

The 'ESCAPE' key is used to cancel temporarily an overload or an A2B condition. If the following message is displayed:



The operator can bypass the lockout system in case of an emergency by pressing the 'ESCAPE' key. This key must be pressed again after 10 seconds.

When the lockout system is bypassed during an overload situation, the **RED** warning signal flashes. The audible alarm is silent. A bypass message is alternately displayed on screen.



The overload situation can be bypassed when:

- A braking measure is applied and
- There are no faulty sensors.

The bypass is immediately canceled:

- **10 seconds after it has been set or**
- When no brake measure is applied or
- There is a faulty sensor or
- An A2B situation comes up or
- The i4000 system restarts.

4.6 System in absolute limiting mode

Absolute limits are fixed limits. They can be used as absolute reference values.



Please make sure you have read and understood these instructions before defining the operational limits. A wrong setting of operational limits can lead the machine to collide with obstacles and thus cause serious injuries or death.

In absolute limiting mode, the operator can set, activate or deactivate five operational limits.

These are:

Absolute limiter
Min angle reach

1) The minimum boom angle limit.

Absolute limiter
Max angle reach

2) The maximum boom angle limit.

Absolute limiter
Max length reach

3) The maximum boom length limit.

Absolute limiter
Max height reach

4) The maximum boom head height limit.

Absolute limiter
Max radius reach

5) The maximum work radius limit.



Important: Please note that no brake measures are applied on absolute limits.

4.6.1 Accessing the absolute limiting adjustment mode



1. Navigate to the Indicator tab and then press 'ENTER'.



2. Use the 'UP/DOWN' keys to highlight the 'Set absolute limits' line.

INDICATOR TAB

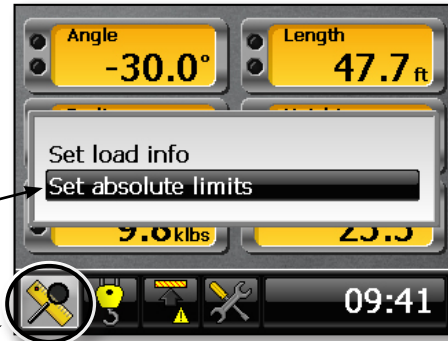

3. Press 'ENTER' to confirm your choice and access the adjustment mode.



4. Press 'ENTER' at the 'Select limit' line then press the 'UP/DOWN' keys to choose the limit you wish to adjust.

Select limit	Max angle
limit enabled	Off
Set value	65.0



5. Press 'ENTER' to confirm your choice.

4.6.2 Activating or deactivating an absolute limit



1. Use the 'UP/DOWN' keys to highlight the 'Limit enabled' line.

Select limit	Max angle
limit enabled	Off
Set value	72.5



2. Press 'ENTER' to edit the value. Press the 'UP/DOWN' keys to choose between On-Off (active-inactive).



3. Press 'ENTER' to confirm your choice.

4.6.3 Adjusting an absolute limit value

1. Access the absolute limiting adjustment mode(see section 4.6.1).



2. Press 'ENTER' at the 'Select limit' line then press the 'UP/DOWN' keys to choose the limit you wish to adjust.



3. Press 'ENTER' to confirm your choice.



4. Scroll down to the 'Set value' line then press 'ENTER'.

Select limit	Max angle
limit enabled	Off
Set value	72.5



5. Change the first digit by entering your desired value, using the 'UP/DOWN' keys.



6. Press 'ENTER' to move to the second digit.



7. Repeat steps 5 and 6 for the following digits. After entering the last digit, press 'ENTER' again to save the value.



Press the 'LEFT' key to go back to the previous digit.
Press the 'RIGHT' key to go to the next digit.



At any time, press the 'ESCAPE' key to go back without saving changes.

4.7 Range limiting mode warnings



Please make sure you read and understand these instructions before defining a limit. A wrong setting of limits can lead the machine to accidentally collide with obstacles, causing serious injuries or death.



MOVEMENT OF THE CRANE IS FORBIDDEN WHEN THE RANGE LIMITING DEVICE IS ACTIVATED.



The limits must be reset each time the crane is moved.





RaycoWylie recognizes that operating a crane near power lines or machinery is an extremely dangerous practice which calls for additional precautions. To prevent the risk of electrocution, it is therefore essential to operate the crane outside of the minimum distances authorized, so that there is no possibility that the crane, the lifting rope or the load become an electrically conductive path. The crane should never be used to move around the material stored under power lines, except if a combination of boom, load, load line, or machine cannot penetrate in the forbidden zone. The range limiting device option of the i4000 system should never be used to delimit the forbidden zone. Please consult the national, state, or local safety regulations applicable to his work, in order to learn more about operating cranes close to power lines.

4.7.1 Range limiting option

The system includes the Range limiting device option. When a rotation sensor is installed on the crane, and the Range limiting device of the i4000 system is activated, a new tab will appear on the selection bar.

The yellow bar shows the moving boom position.

 A yellow arrow indicates an approaching limit.

 A red arrow indicates a reached limit.

Show the zones which are programmed:

The dial on the left shows a view from above:
-the radius limit as well as the left and right walls will be shown in red.

The dial on the right shows a view from the side:
- the height limit will be shown in red.

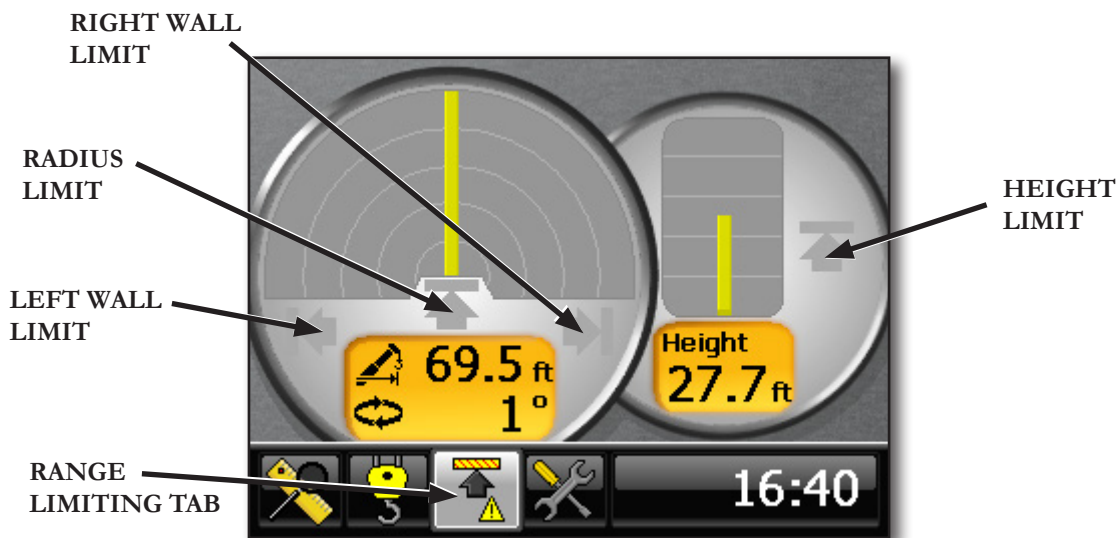

4.7.2 Accessing the range limiting adjustment menu



Once the Range limiting tab is highlighted, press 'ENTER' to view a list of limits available for programming:

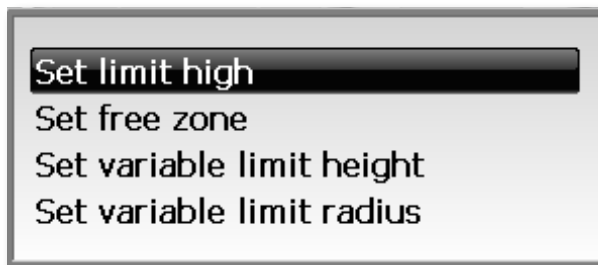

4.7.3 Height Limit

The height limit is the maximum boom tip height desired. We can also consider that is a ceiling of fixed height on 360 °.



1. When in the range limiting tab, press the 'ENTER' key to access the range limiting adjustment menu.



2. The «Set limit high» line is highlighted by default. If it is not the case scroll up or down to highlight this line.

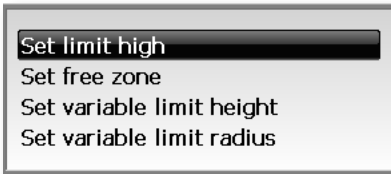

3. Press the **Select** button to confirm your choice.

4. Boom up to the desired boom tip height limit.



5. Press the Select button to confirm the maximum boom tip height position.

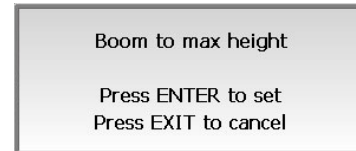

6. As you release the **Select** button, a 10 seconds countdown will allow you to boom down before your programmed height limit becomes active.

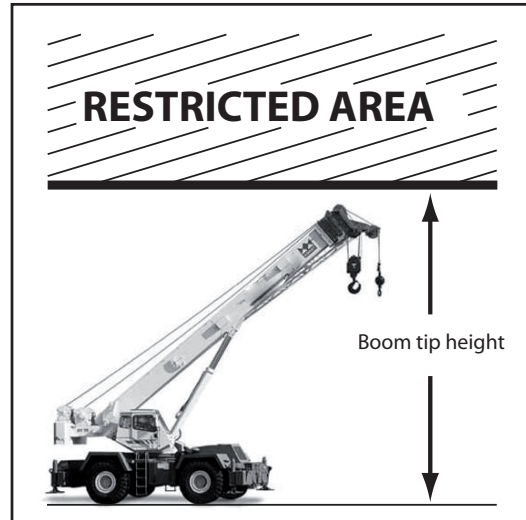

Height limit programmed (RED ZONE)

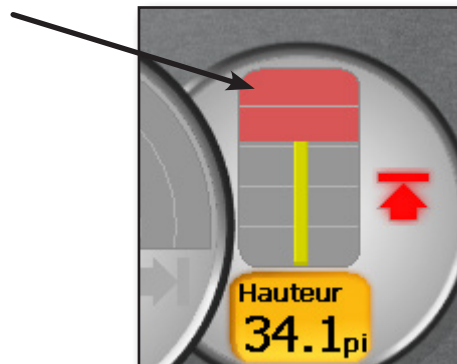

Height limit reached 

Height limit approached 

4.7.4 Free zone

The free zone is a zone without height limit. The free zone is limited by 2 walls each side where the boom cannot access over these walls.



1. When in the range limiting tab, press the 'ENTER' key to access the range limiting adjustment menu.



2. Scroll up or down to highlight the «Set free zone» line.

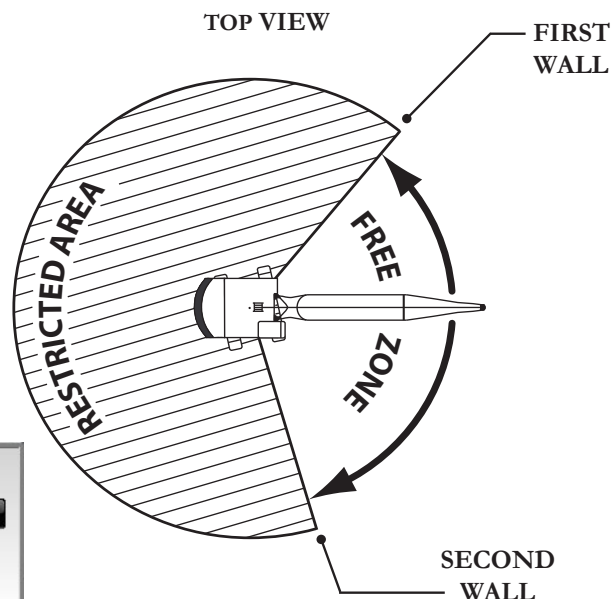
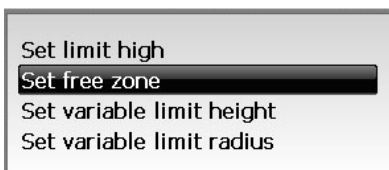

3. Press the **Select** button to confirm your choice.

4. Turn the crane and establish the position of the first limit (first wall).

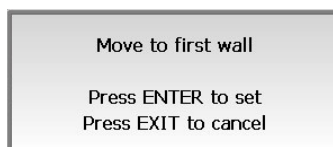

5. Press 'ENTER' to confirm the position of the first wall.

6. Turn the crane and establish the position of the second limit (second wall).

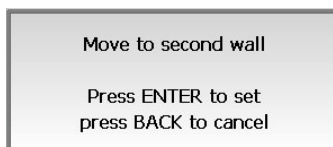

7. Press 'ENTER' to confirm the position of the second wall. After you release the key, you will have a 10 second countdown to pivot the crane between both walls before your programmed limit is activated.

4.7.4 Free zone (cont.)

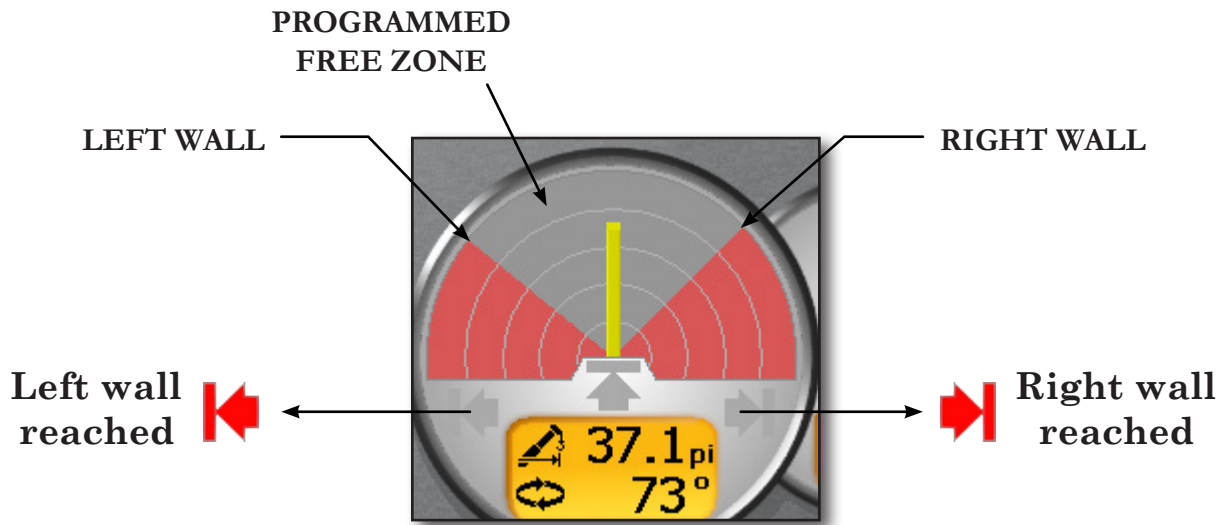

4.7.5 Variable height limit

A variable height limit is a height limit which can vary in function of the rotation of the boom (variable ceiling). Depending on the configuration of the obstacle, it may be necessary to limit to a certain height for a position and at different height for another position.



1. When in the range limiting tab, press the 'ENTER' key to access the range limiting adjustment menu.



2. Scroll up or down to highlight the «Set variable limit height» line.

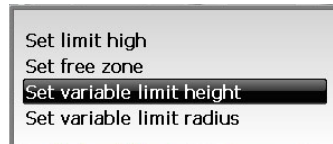

3. Press the **Select** button to confirm your choice.

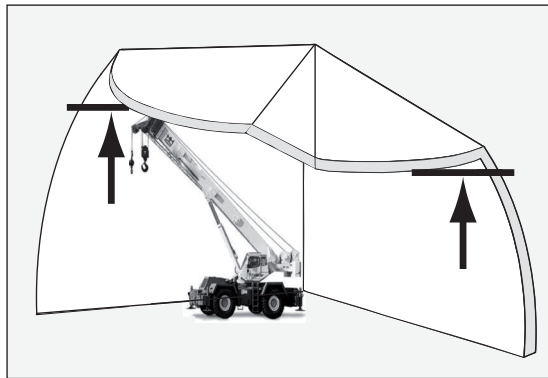

4.7.5 Variable Height Limit (cont.)

- Rotate the crane until you reach the position of your first limit (first wall).

Move to first wall
Press ENTER to set
Press EXIT to cancel



- Press the **Select** button to confirm the position of your first limit.
- Rotate the crane toward the second limit position (second wall) with the boom tip always at the maximum height permitted by the surrounding environment .

Turn and boom up or down
then press ENTER to place
second wall
press BACK to cancel



- Press **Select** button to confirm the position of the second wall.
- As you release the **Select** button, a 10 seconds countdown will allow you to return between the two walls and boom down before your programmed Variable Height Limit becomes active.

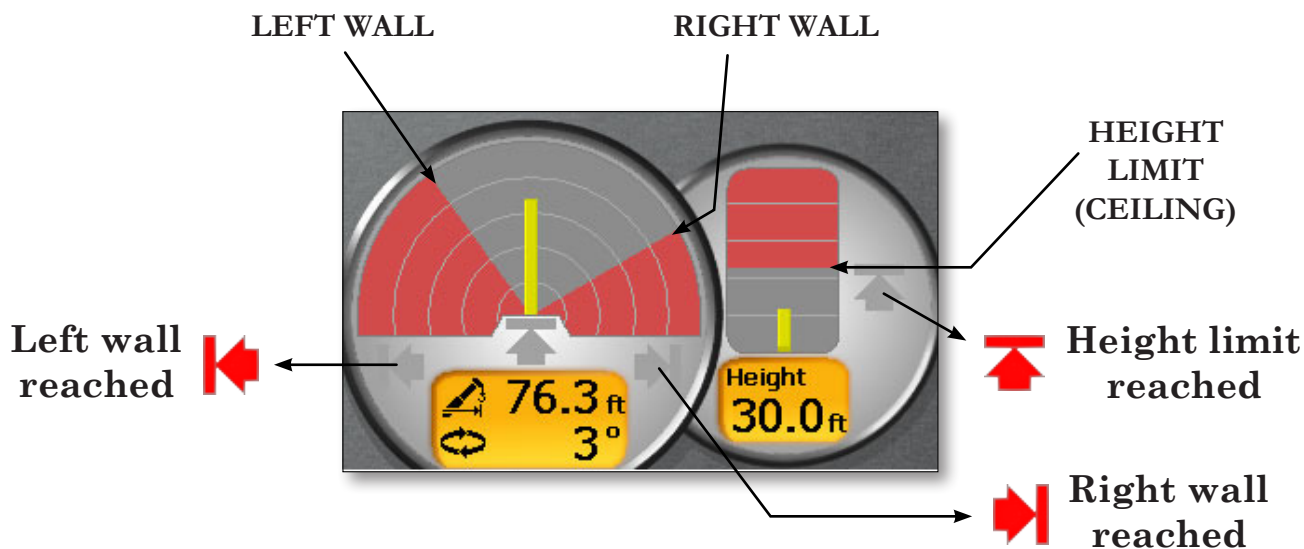

4.7.6 Variable radius limit

A variable radius limit is a radius limit which can vary in function of the rotation of the boom. Depending the configuration of the obstacle, it may be necessary to limit to a certain radius for a position and another radius for another position.



1. When in the range limiting tab, press the 'ENTER' key to access the range limiting adjustment menu.



2. Scroll up or down to highlight the «**Set variable limit radius**» line.

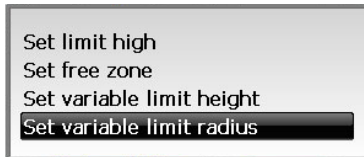

3. Press the **Select** button to confirm your choice.

4. Rotate the crane until you reach the position of your first limit (first wall).

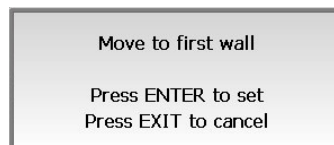

5. Press the **Select** button to confirm the position of your first limit.

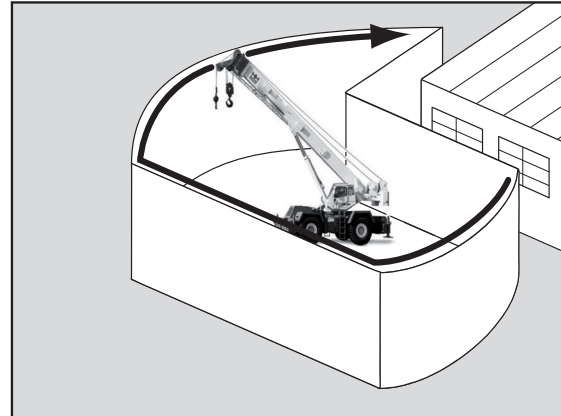

4.7.6 Variable radius limit (cont.)

6. Rotate the crane toward the second limit position (second wall) with the boom tip always at the maximum radius permitted by the surrounding environment .

Turn and extend or retract
then press ENTER to place
second wall
press BACK to cancel



7. Press **Select** button to confirm the position of the second wall.
8. As you release the **Select** button, a 10 seconds countdown will allow you to return between the two walls and boom up within the allowed radius limit before your programmed Variable Radius Limit becomes active.

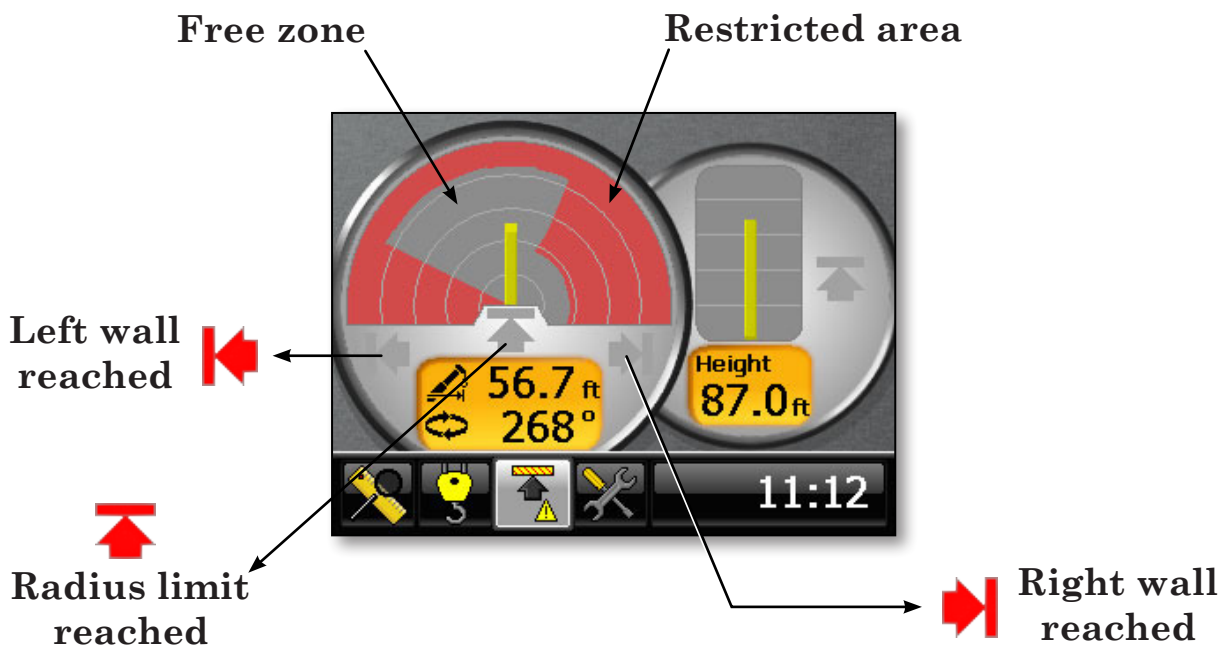

-5-

Diagnostic and maintenance



Warning! Maintenance must be performed by a qualified technician, or by an operator aided by a RaycoWylie technician.

In this section you will find the necessary technical assistance for performing the maintenance. This section provides answers to the questions frequently asked to the personnel during installation, reparation, or maintenance of the i4000 system.

5.1 Diagnostic menu

A diagnostic menu provides information on the system status as well as on the status of all the connected sensors.

To access the diagnostic menu:



1. Navigate to the Tools tab with the LEFT or RIGHT keys.



2. Use the 'UP/DOWN' keys to highlight the diagnostic line.



3. Press the 'ENTER' key to access the diagnostic menu.

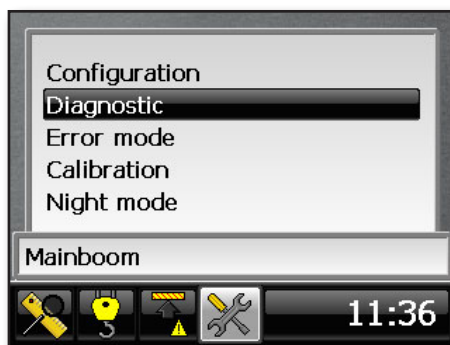

5.1 Diagnostic menu (cont.)

Each line in the diagnostic menu will open up another page when you select it and press 'ENTER'. Each page deals with a specific type of sensor or a particular type of information.

Independently of the system configuration, the following 2 pages are always accessible: Addresses detected and System.

Additional pages are optional and they are only visible if one or several sensors are activated (refer to the option «Activate / Deactivate I / O» in the calibration menu).

The 'UP/DOWN' keys allow the user to navigate within the diagnostic menu.

In the diagnostic menu, this is the information normally shown:

SENSOR'S CONNECTION
STATUS

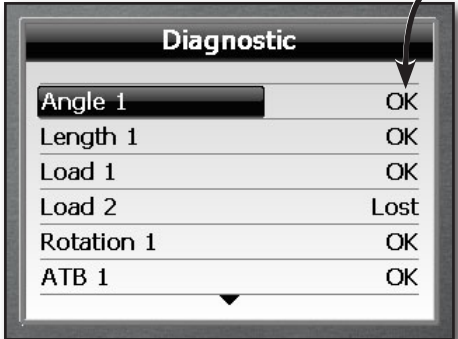

The screenshot shows a window titled "Diagnostic" with a list of sensors and their connection status. An arrow points from the text "SENSOR'S CONNECTION STATUS" to the status column of the table.

Diagnostic	
Angle 1	OK
Length 1	OK
Load 1	OK
Load 2	Lost
Rotation 1	OK
ATB 1	OK

Certain applications have more than one angle, length, or load sensor. In such case, the pages showing these sensors will equally appear in this menu.

The second column shows the connection status of the sensor in the CAN Bus network.



Press 'ESCAPE' to access the previous menu or to quit the diagnostic mode.

5.2 Angle and Length sensor



Angle sensor 1 and length sensor 1 are placed physically on the same electronic board.



Press 'ENTER' when «Angle 1» is highlighted to view the name and version of the angle sensor software as well as its calibration status. The information shown will look like this:

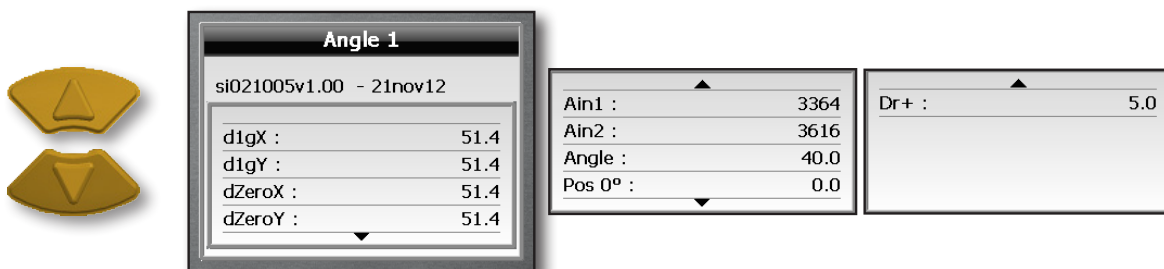

These values will allow the RaycoWylie technician to diagnose a problem in the sensor. In case of an angle sensor multifunction, take note of these values and report them to a RaycoWylie Systems technician.



Press 'ESCAPE' to go back to the main screen of the diagnostic mode.



Press 'ENTER' when «Length 1» is highlighted to view the calibration status of the extension sensor. The information shown will look like this:

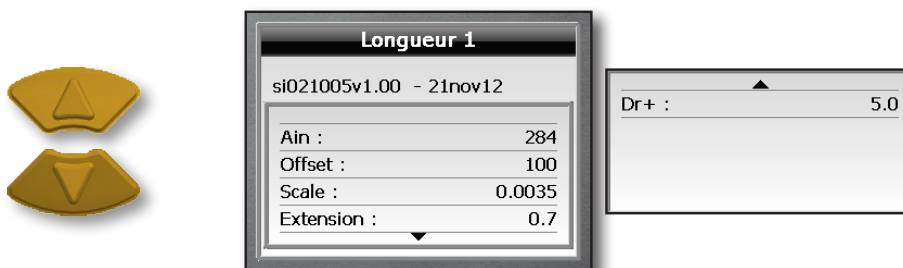

The following are the basic criteria for a proper functioning of the length sensor:

- The value of the Scale factor must be less than 1,0.
- **Dr+** must be close to **5,00** DC volts.

5.3 Load sensor

To find out about the load sensor software version or calibration status, press 'ENTER' when the line «Load 1» is highlighted.

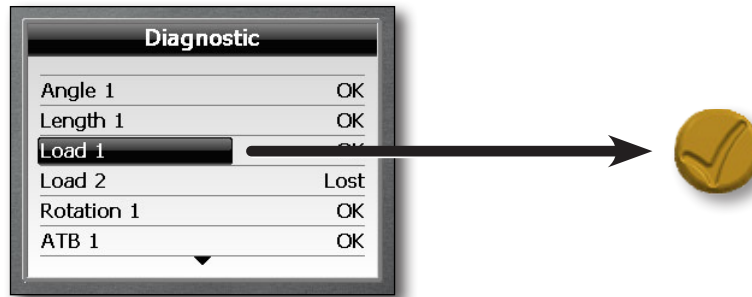

The information displayed will look like this:

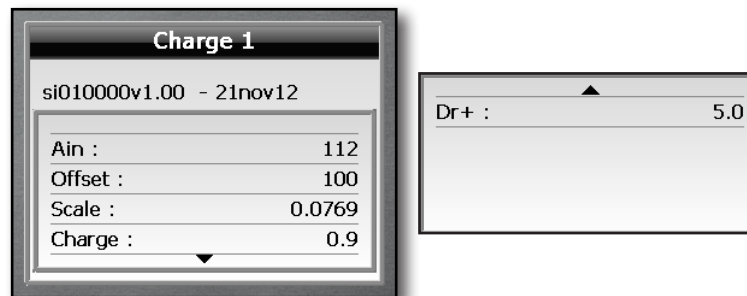

The following are the basic criteria for a proper functioning of the load sensor:

- The value of the Scale factor must be less than 1,0.
- Dr+ must be close to **5,00** DC volts.



Press 'ESCAPE' to go back to the main screen of the diagnostic mode.

5.4 Detected addresses

This page of the diagnostic menu displays the addresses of the different sensors on the bus CAN network detected by the i4000 system. The addresses remain in the memory as long as the system is on, even if a sensor stops sending information.

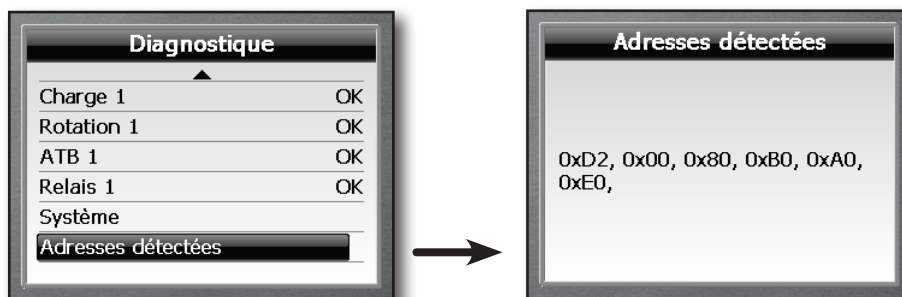

5.5 Error messages

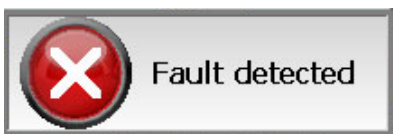

At power-up and during other processes, the i4000 system analyzes all the interactions between the internal peripherals (memories, controllers, extension boards) and the external peripherals (physical boards connected with the CAN Bus network). The system error indicator will appear on the main screen if an error is detected.

5.5.1 Internal peripherals

*If you have any questions or need assistance, please contact the **RaycoWylie** technical assistance department.*

Error message	Runtime process	Error cause
Read calibration Read canbus config. Read logger Read absolute limiter	During start-up, the system runs an integrity check of all the data in the flash memory (CRC).	There is a problem with the flash memory of the system in the display of the i4000. Contact the RaycoWylie technical assistance department.
Bus Off	Verification of the bus CAN controller.	1) There is a physical problem on the CAN network.. Contact the RaycoWylie technical assistance department.
Calib. parameter	The crane's dimensions must be correctly entered, otherwise the load value could be null or wrong.	The value of variables CL1, CL2 and CL2MR should never be zero.

5.5.2 External peripherals

A) Angle / Length interface and A2B errors

The i4000 system can communicate with 1 angle/length interface. Each sensor is activated through the calibration menu in the “**Enable/Disable sensors**” section.

Error message	Runtime process	Error cause
Angle 1: Sensor fail	The value of the sensor’s signal in volts is not valid (1 to 4 volts).	1) The 12 bit converter or accelerometer is faulty.
Length 1: Sensor fail	A code is sent by the angle/length interface to indicate that the length sensor is disconnected.	1) The length sensor is not installed. 2) A cable between the length sensor and the interface is broken.
Angle 1: In prod. Cal		Indicates that the angle/length interface is in pre calibration mode.
Angle 1: Lost communication Length 1: Lost communication	The system has not received a valid message from the Angle/Length interface within the required time frame.	1) The Angle/Length interface is faulty. 2) The cable linking the interface to the bus CAN network is broken.
Length 1: Is not calib.		The Length sensor is not calibrated.
Angle 1: Is not calib.		The Angle sensor is not calibrated.
Angle 1: DR+ fail Length 1: DR+ fail	The 5 Volts reference tension is not valid (If < 4.5 volts or > 5.5 volts).	The Angle/Length interface circuit is faulty.

5.5.2 External peripherals (cont.)

B) Load interface error

The i4000 system can communicate with 2 load interfaces. Each sensor is activated through the calibration menu in the **“Enable/Disable sensors”** section.

Error message	Runtime process	Error cause
Load 1 (or 2): Sensor fail	The value of the load sensor signal in bits is not valid (If < 150 or > 3945).	1) The 12 bit converter or amplifier is faulty. 2) The cable linking the load sensor and the interface is broken.
Load 1 (or 2): Not calib		The load 1 or load 2 sensor is not calibrated.
Load 1 (or 2): Dr+ fail	The 5 Volts reference tension is not valid (If < 4.5 volts or > 5.5 volts).	The load interface circuit is faulty.
Load 1 (or 2): Lost communication	The system has not received a valid message from the Load interface within the required time frame.	1) The Load interface is faulty.. 2) The cable linking the interface to the bus CAN network is broken.

C) Relay interface and digital input error.

The i4000 system can communicate with 1 relay interface and digital input. Each relay interface is activated through the calibration menu in the **“Enable/Disable sensors”** section.

Error message	Runtime process	Error cause
Relay 1: Lost communication	The system has not received a valid message from the relay interface within the required time frame.	1) The relay interface is faulty.. 2) The cable linking the interface to the bus CAN network is broken.



There is no automatic test to verify the relay output contacts. As a result, if a relay contact is faulty, this error cannot be detected by the system. The operator should periodically test the proper functioning of the lockout system.

5.5.2 External peripherals (cont.)

D) Rotation Sensor J1939 error

Absolute rotation

The i4000 system can communicate with only one rotation sensor. The rotation interface is activated through the calibration menu in the **“Enable/Disable sensors”** section.

Absolute rotation (same position kept at all times)

Error message	Runtime process	Error cause
Rotation 1: Ratio not set	The system detects a ratio of 0.	No ratio has been entered or calibrated.
Rotation 1: Lost communication	The system has not received a valid message from the rotation interface within the required time frame.	1) The rotation interface is faulty. 2) The cable linking the interface to the bus CAN network is broken.

-6-

Inspections and maintenance

6.1 Frequent inspections

(Performed each time the crane is used)

- When you switch on the system, check if all the alarm lights, audible alarms, and lockout are working.
- Make sure the system is correctly configured.
- Check the accuracy of the clock.
- Make sure the system has not detected any errors.
- Check the weight on the hook (it should be the same as the last time you checked).
- Check the radius according to the boom selection. The radius displayed should be between 0 and 10 % larger than the current radius of the crane.
- Check that the A2B is functioning properly.



Careful! Before using the machine, you should identify any defects and assess if they can have serious consequences.

6.2 Periodic inspections (every six months)

Please perform regular inspections of:

- The cables (verify they are not cut or damaged) and the connectors (verify the contacts are not corroded).
- The rope drum is securely fixed to the extremity of the boom.
- The A2B switch piston to see that there is not too much corrosion.
- The A2B switch piston to see that there is not too much corrosion.
- Relay functionality for the lockout.

6.3 Checking the displayed load

- Position and level the machine.
- The person who does the test should be qualified to operate the crane and the i4000 system.
- The crane and the system must be correctly configured.
- The capacity chart must be respected.
- A known weight, accurate by $\pm 1\%$ and equal to the nominal capacity close to the maximum radius should be used to test the alarm and the load indicator's accuracy.
- Another known weight, accurate by $\pm 1\%$ and equal to the nominal capacity close to the minimum radius should be used to test the alarm and the load indicator's accuracy.
- Rig with enough strands to lift a significant load.
- Measure and enter the radius and the load on the hook.
- Record the radius, length, load on hook, and number of strands on the display unit's screen.
- Lift the load.
- Enter the current weight including the hook and the rigging accessories.
- Record the average, maximum, and minimum values.
- Rig the hoist, stop and record the same values than in the previous step.
- Record the current and displayed radius.
- Lower the load.
- **RaycoWylie** recommends that all tests be signed and dated, and a copy of the last test be available at all times.

6.4 Maintenance



Unless otherwise specified by a RaycoWylie technician, all (original and replacement) parts must be provided by RaycoWylie.

Preventive maintenance

- Your i4000 system has been designed to work during long periods, requiring the least maintenance possible. However, the system does need to be maintained and cleaned to function properly.



Important: Do not clean the i4000 display unit, the junction boxes, the angle sensors, load cells, and connectors with a high-pressure air stream. This could cause mold to appear in the connectors, and a possible failure of the sensors.

- Use a soft soap (or a glass cleaner) and a soft cloth to wash the surface of the display unit.



Important: If you see condensation forming inside the display unit's screen, open the cover and let it dry for a whole day in a dry place.

- Replace all cables that might be damaged. Check that the contacts of the connectors are not corroded.
- Replace the rope drum brushes if they show signs of wear.
- Replace the A2B switches if the piston is too corroded.



*In order to ensure that the i4000 display is water resistant, make sure the back has an X-shaped **tightening**.*

Your i4000 system does not need any additional lubrication.

6.5 Maintenance procedure



Before making any adjustments or repairs on the crane, make sure you take these precautions.

- Place the crane where it will not disturb other machines or operations in progress.
- Lock out all commands and make sure all functions are rendered inoperative.
- Make sure you lock out the start-up commands.
- Lower the boom to the ground if possible, or prevent it from falling.
- Lower the pulley block to the ground if possible, or prevent it from falling.
- Increase the hydraulic pressure of all hydraulic circuits before releasing or lifting the hydraulic components.
- A «Danger» or « Broken» sign should be placed on the crane commands, to be removed only by authorized personnel.
- Once the adjustments and repairs are finished, the crane should still not be used until all the safety devices have been activated and the air released from the hydraulic system. The instructions to release the air from the hydraulic systems should be provided by the crane manufacturer.

6.6 Adjustments and repairs

- All unsafe conditions noted during an inspection should be fixed before using the crane again.



Important: Only qualified personnel should perform the adjustments and repairs.

All adjustments should be made in compliance with the tolerated values specified by RaycoWylie in order to keep each system component in proper working condition.

- If you need spare parts to complete the maintenance or repairs, please contact the **RaycoWylie** technical assistance department.



If you have any questions or need assistance, please contact our technical assistance department. Have your i4000 system's serial number handy.

