

MICROGUARD[®]

TEREX RCI 500

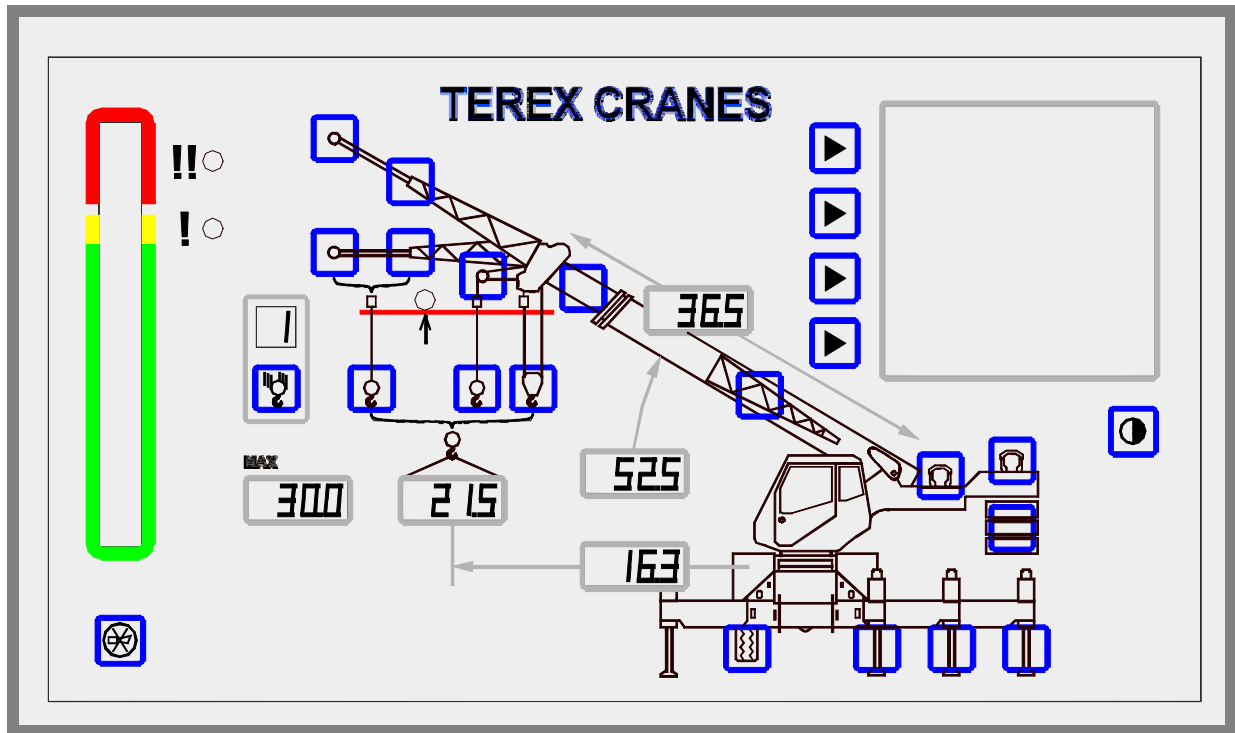

TROUBLESHOOTING MANUAL



TABLE OF CONTENTS

TEREX RCI 500 TROUBLESHOOTING MANUAL

System Description	3
Fault Diagnostic Procedures	4
Fault Codes	5-6
Voltage Checks – Power Supply Voltages	7
The Processor Board and the Termination Board	8-9
Checking the Analog Drive Voltage	9
Pressure Channel Fault Guide - Functional Tests	
Pressure Transducers	10-11
Analog Drive Voltage	12
Boom Extension Sensor AIN2	13-14
Boom Angle Sensor AIN3	15
Swing Potentiometer AIN5 and AIN6	16
No Duty Found	17
Other System Faults	17
Executive ROM	17
Personality ROM	17
Scratchpad RAM	17
Duty ROM	17
Current Duty Bad	17
Configuration – Not Calibrated	17
Digital and Analog I/O	17
Display Unit	17
Anti Two-Block System	18-19
Pressure Transducer Replacement	20
Extension Reel Replacement	20
Boom Angle Sensor Replacement	20-21
Chip Replacement	
Executive ROM Chip Replacement	21
Personality ROM Chip Replacement	21
Duty ROM Chip Replacement	21
Processor Board Replacement	21-22
Terminal Board and Box Replacement	22
Chip Removal and Installation	22
Processor Board Layout	23
Termination Board Layout	24
Extension Reel Layout	25
Glossary	26-31

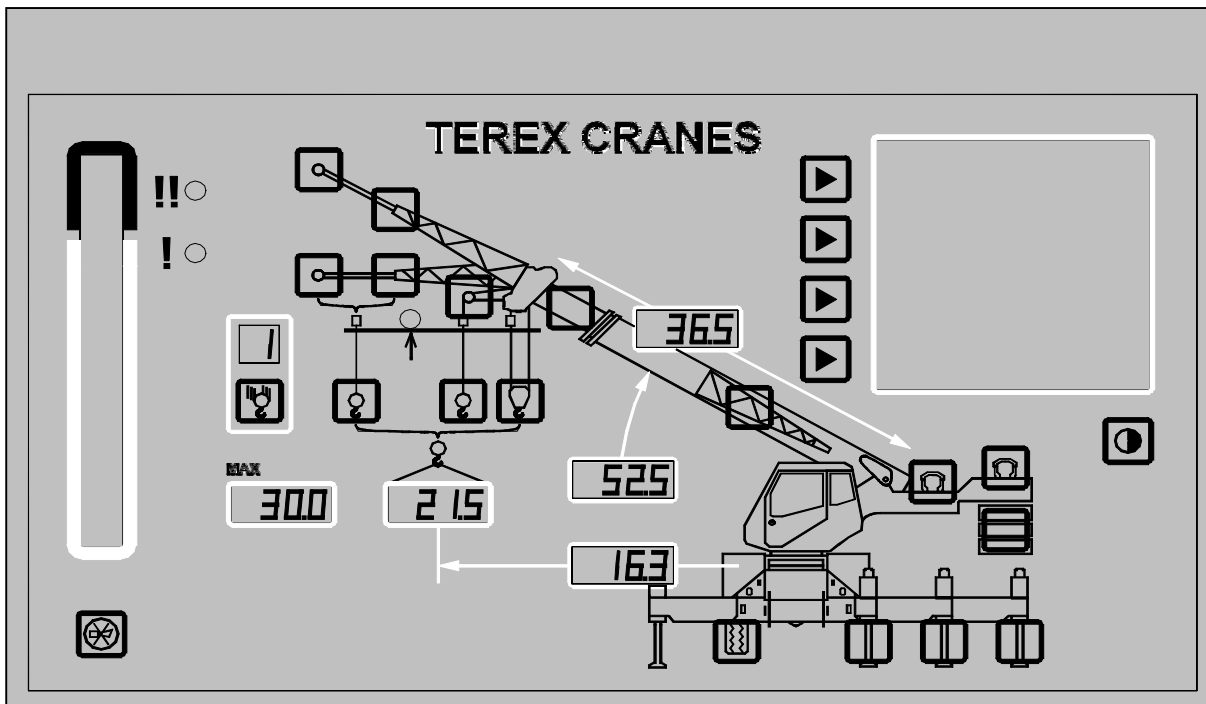

SYSTEM DESCRIPTION

The Terex RCI-500 System is intended to aid the crane operator in the efficient operation of the crane by continuously monitoring the load and by warning of an approach to an overload or two-block condition.

The Terex RCI-500 System monitors crane functions by means of high accuracy sensors that continuously compare the load suspended below the boom head with data from the crane capacity chart stored in the memory of the computer. If an overload is approached, the system warns the operator by means of audible and visual alarms. The system can also be configured to cause function kick-out.

The MicroGuard® RCI 500 indicator provides the operator with a continuous display of:

- Rated Capacity
- Actual Load
- Percentage of Rated Capacity
- Radius of the Load
- Angle of the Main Boom
- Working Area
- Crane Configuration
- Length of the Main Boom

On-screen messages provide the operator with visual indications of the various alarms that may occur during normal operation of the RCI-500 System. These values appear on the left display. The right display gives information about the currently selected crane configuration.

FAULT DIAGNOSTIC PROCEDURES

Faults in the RCI-500 System are detected at start-up with an automatic self-test that lasts about 2-3 seconds. This self-test is activated each time the system is switched on. During normal operation, a self-test can be initiated at any time by pressing and holding the red TEST button on the right of the display.

Fault conditions in external sensors are detected without the need for a system self-test.

Faults detected in the system during a self-test, are identified on the display as follows:

- The word "FAULT" will appear in the information area.
- The RED LAMP will illuminate.
- The AUDIBLE ALARM will sound.

Faults occurring in the system can be diagnosed using the display.

1. PRESS and HOLD the TEST button to initiate the self-test and to identify any faults.

2. Continue to PRESS the TEST button.

NOTE: Following the self-test, faults found will be identified on the display screen and will remain visible as long as the operator continues to press the TEST button.

3. Fault information will appear on the screen in the following four groups.

- Group A Sensor Faults
- Group B I/O Faults
- Group C Memory Faults
- Group D General Faults

FAULT CODES

GROUP "A" – ANALOG SENSORS

CODE

AAA		
000		NO FAULTS
001	AIN0	PISTON PRESSURE TRANSDUCER
002	AIN1	ROD PRESSURE TRANSDUCER
004	AIN2	EXTENSION SENSOR
008	AIN3	BOOM ANGLE SENSOR
016	AIN4	NOT USED
032	AIN5	SWING POTENTIOMETER "A"
064	AIN6	SWING POTENTIOMETER "B"

GROUP "B" – INPUTS AND OUTPUTS

CODE

BB		
00		NO FAULTS
01	1	DIGITAL INPUT AND OUTPUT
02	2	ANALOG INPUT AND OUTPUT
04	4	DISPLAY UNIT

GROUP "C" – MEMORY

CODE

CC		
00		NO FAULTS
01	1	EXECUTIVE ROM
02	2	DUTY ROM
04	4	SCRATCHPAD RAM
08	8	PERSONALITY ROM

GROUP "D" – GENERAL

CODE

DD		
00		NO FAULTS
01	1	NO DUTY FOUND
02	2	CURRENT DUTY BAD
04	4	CONFIGURATION UNCALIBRATED

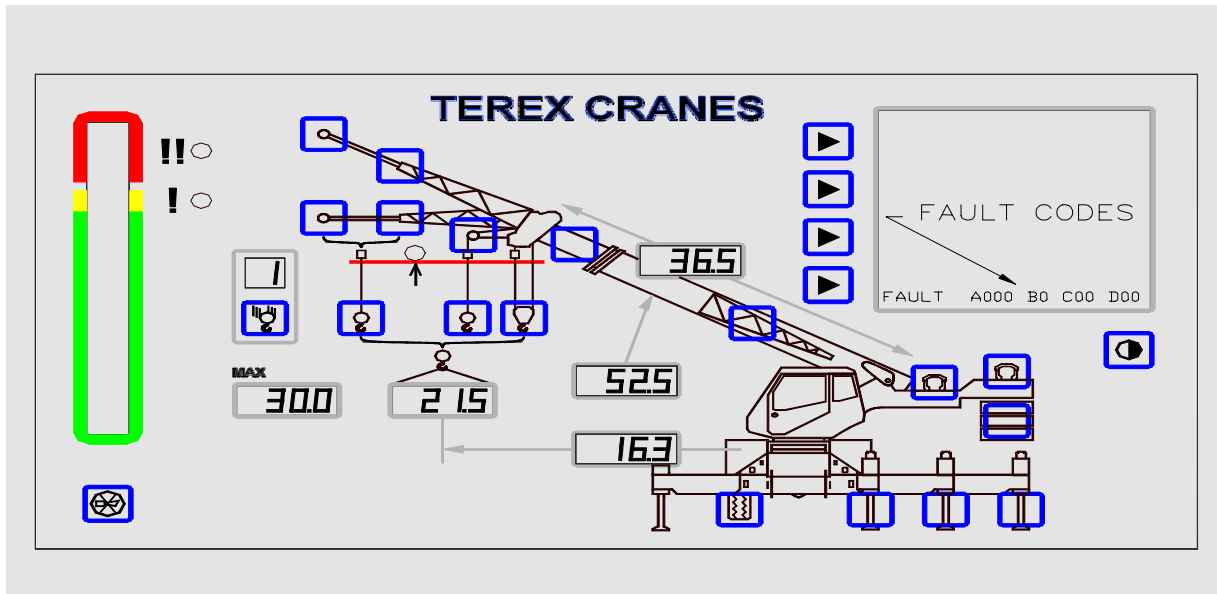

GROUP ‘A’ FAULT CODES

When a fault is detected by the system, a number will appear under one or more of the four group headings A through D, shown on the previous page. This number will correspond to one or more fault diagnostic numbers. The meaning of these numbers can be determined by looking at the appropriate code in the fault interpretation table.

Fault codes in Group A relate to analog sensors. Each sensor is allocated a number. This number is also the number of the channel to which it is connected in the system.

- Sensor 0 Piston Pressure
- Sensor 1 Rod Pressure
- Sensor 2 Extension Sensor
- Sensor 3 Boom Angle
- Sensor 4 Not Used
- Sensor 5 Swing Pot'r "A"
- Sensor 6 Swing Pot'r "B"

Each sensor is allocated a FAULT CODE. This code number appears under the group heading in the fault code display.

001	Sensor 0	Piston Pressure
002	Sensor 1	Rod Pressure
004	Sensor 2	Extension Sensor
008	Sensor 3	Boom Angle
032	Sensor 5	Swing Pot'r "A"
064	Sensor 6	Swing Pot'r "B"

When no faults are detected in the system, '000' will appear under all group headings.

When there are faults in only one sensor, one of the above codes will be listed.

When there are faults in more than one sensor, the codes indicated will be the sum of the fault codes.

EXAMPLES OF FAULT CODES:**Fault 0**

AAA	B	CC	DD
000	0	00	00

No faults detected.

Fault 1

AAA	B	CC	DD
001	0	00	00

Piston pressure transducer.

Fault 2

AAA	B	CC	DD
002	0	00	00

Rod pressure transducer

Fault 3

AAA	B	CC	DD
003	0	00	00

Piston pressure transducer

Rod pressure transducer

Fault 4

AAA	B	CC	DD
004	0	00	00

Extension Sensor

Fault 5

AAA	B	CC	DD
005	0	00	00

Piston pressure transducer

Extension sensor

Fault 6

AAA	B	CC	DD
006	0	00	00

Rod pressure transducer

Extension sensor

Rod pressure transducer

Fault 7

AAA	B	CC	DD
007	0	00	00

Piston pressure transducer

Rod pressure transducer

Extension sensor

Fault 8

AAA	B	CC	DD
008	0	00	00

Boom angle sensor

Fault 9

AAA	B	CC	DD
009	0	00	00

Piston pressure transducer

Boom angle sensor

Fault 10

AAA	B	CC	DD
010	0	00	00

Boom angle sensor

Rod pressure transducer

Fault 11

AAA	B	CC	DD
011	0	00	00

Boom angle sensor

Piston pressure transducer

Rod pressure transducer

Fault 32

AAA	B	CC	DD
032	0	00	00

Swing potentiometer "A"

Fault 64

AAA	B	CC	DD
064	0	00	00

Swing potentiometer "B"

Fault 96

AAA	B	CC	DD
096	0	00	00

Swing potentiometer "A"

Swing potentiometer "B"

This sequence continues up to the maximum fault code of 127, which is the sum of all "GROUP A" fault codes.

Fault 127

AAA	B	CC	DD
127	0	00	00

All analog sensors.

This fault condition is seldom caused by the simultaneous failure of all sensors. It is usually the result of the failure of the analog drive voltage, which supplies the voltage for all sensors. This power supply fault may be due to the failure of the power supply or may be due to damage to the cable that connects the sensor to the computer.

When this fault occurs, carry out Power Supply Voltage checks before checking individual sensors.

VOLTAGE CHECKS**POWER SUPPLY VOLTAGES**

The Computer Unit contains 2 major boards: the Processor Board and the Termination Board. Both of these assemblies are located in an aluminum box that is usually located on the rear wall of the cab and can be inside or outside the cab depending on crane model. All of the cables from the various sensors and the display are connected to the Termination Board. To access the Termination Board, refer to Page 8 of this manual.

INPUT POWER

The computer operates from an input voltage in a range from 9 to 36 volts DC. This input voltage is measured across the B+ and B- terminals on the Termination Board and corresponds to the battery voltage of the crane. At voltages below 9 and above 36 volts, the system will power down until correct voltage is restored.

If the INPUT POWER is not within these limits, check the battery and/or alternator before servicing the computer.

INTERNAL POWER SUPPLIES

The computer generates its own internal power from the incoming battery voltage.

This power can be monitored at the test points inside the computer adjacent to the fuses and Battery Input Terminals.

To monitor the internal power supplies, use a digital voltmeter set to the appropriate DC voltage range.

Connect the black (-ve) lead to GND

Connect the red (+ve) lead in turn to

+15V +/- 0.1

-15V +/- 0.1

+5V +/- 0.1

If the voltages are out of range, it may be necessary to replace the computer.

Before replacing the computer, call the Product Support Department at the Greer Company, Telephone: 714-259-9702

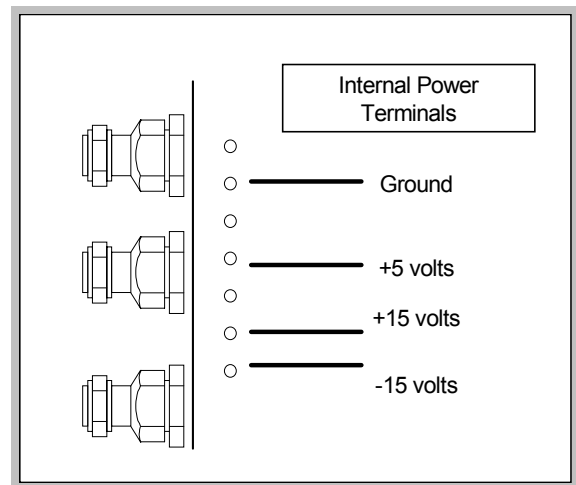
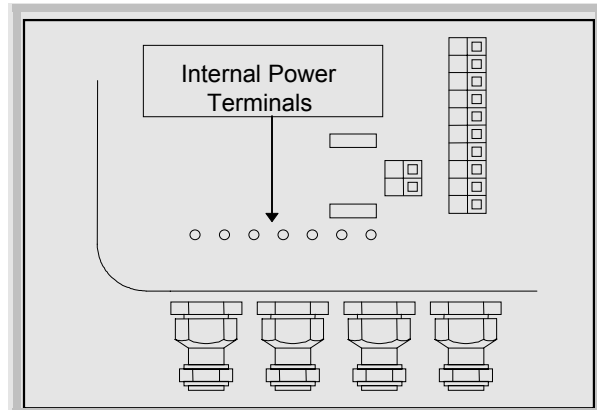

THE PROCESSOR BOARD AND THE TERMINATION BOARD

- Remove the four screws (B) that secure the lid (A) to the computer box (G). Remove the lid and set it aside.
Warning: The lid is NOT hinged. Be careful not to allow the lid to slide off the box.
- Below the lid is the Processor Board (E). This board contains the microprocessor and its related components. This unit is held in place by two screws (D) located at the left and right of the Processor Board mounting plate (C). The Processor Board is connected to the Termination Board (H) via 2 ribbon cables (K), positioned side by side, that carry signals to and from the Termination Board. All of the cables from the various sensors and the display console connect to the Termination Board via the glands (J) in the wall of the box. The key switch (F) controls three wires that connect the Processor Board to the Termination Board.

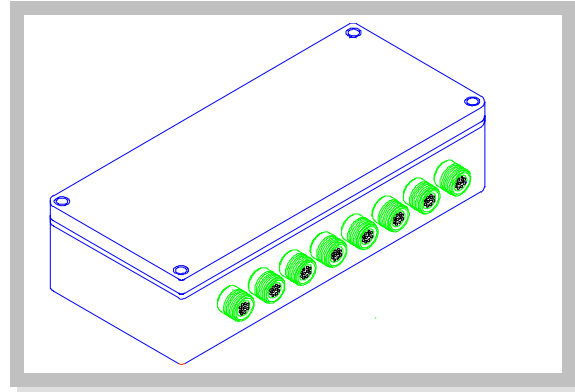

THE COMPUTER BOX

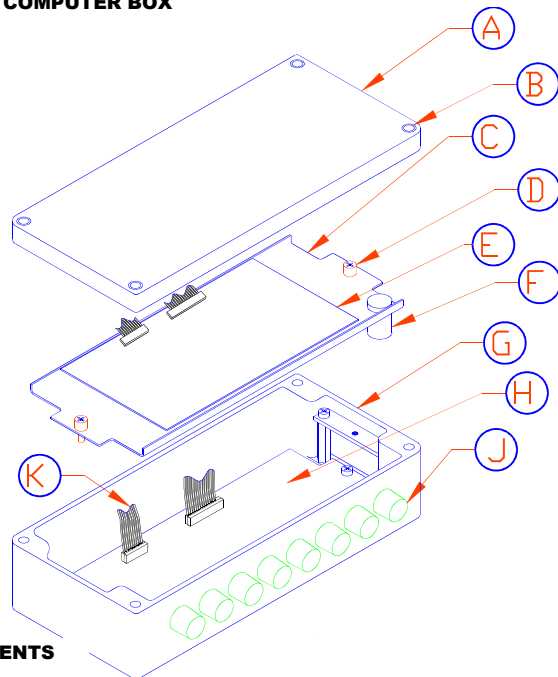

Continued on next page

COMPUTER BOX AND LAYOUT OF THE TERMINATION BOARD

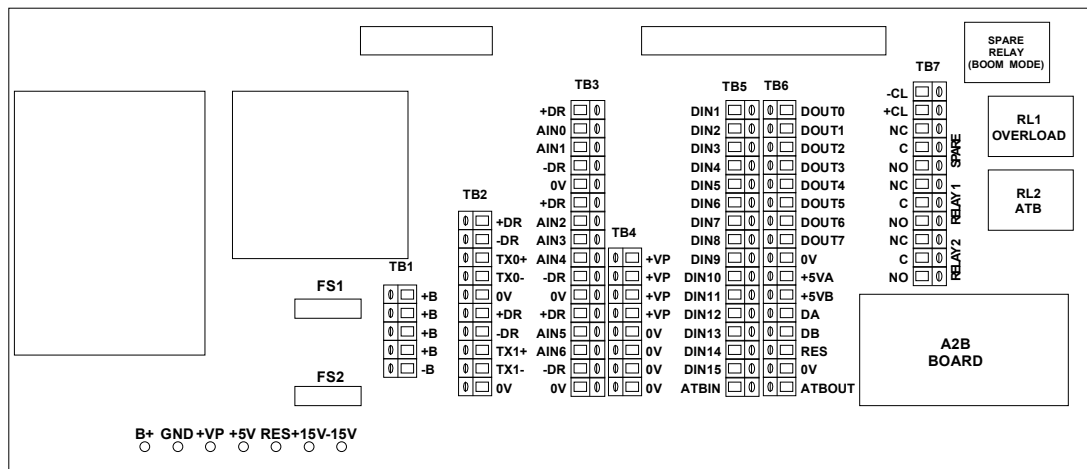

- To check voltages on the Termination Board, remove the two screws located at the left and right of the main computer backing plate and swing the assembly up. Take care not to damage the ribbon cables. These ribbon cables must remain connected to the Processor Board for voltage checks.

CHECKING ANALOG DRIVE VOLTAGE

To check the Analog Sensor Drive Voltage, use the following procedure:

- Access the Termination Board.
- With the system power on and a digital volt meter set to read DC voltage, place the negative lead on any -DR (- Drive) terminal (1) of the Analog Input Group.
- Place the positive lead of the meter on any +DR (+ Drive) terminal (2).
- The voltage should be 5.25+/-0.1volts.
- If the Analog Drive Voltage is not within this range, disconnect all of the external sensor cables, including pressure transducers, cables 1 through 5.
- Recheck the Analog Drive Voltage. If the voltage is still out of range, the Processor Board will need to be replaced. If the voltage is within range, reconnect each cable, one at a time, checking the Analog Drive Voltage after each cable is connected.
- If the Analog Drive Voltage goes out of range after reconnecting any one of the sensors, it is probable that the wiring to the sensor is grounded or the sensor itself is faulty.
Check all wires and the sensor itself and repair or replace, as required.

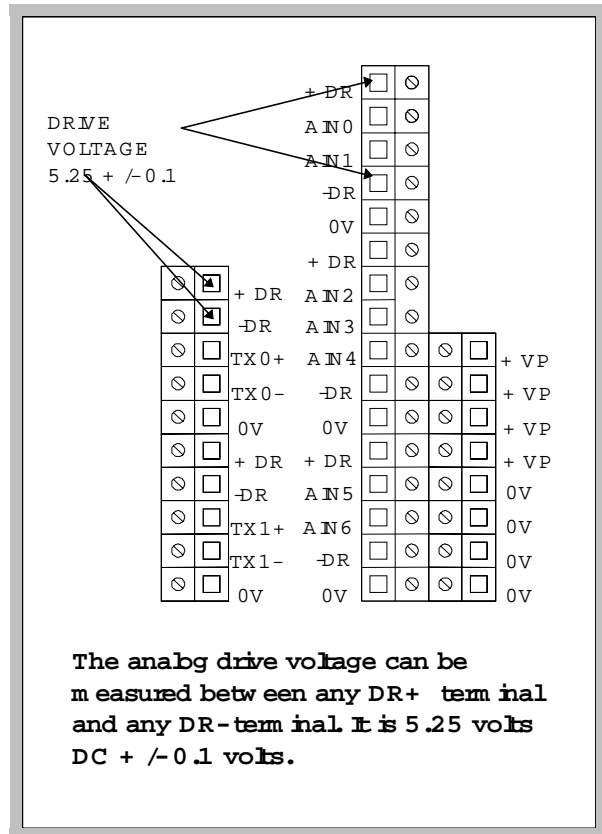

The analog drive voltage can be measured between any DR+ terminal and any DR- terminal. It is 5.25 volts DC +/- 0.1 volts.

Faults in any cable or sensor can cause the analog drive voltage to be faulty.

PRESSURE CHANNEL FAULT GUIDE - FUNCTIONAL TESTS

PRESSURE TRANSDUCERS

A fault in a pressure transducer is such that a fault on one channel can cause an apparent fault in the other channel. It is necessary to test both channels and both transducers together in order to determine which transducer is at fault.

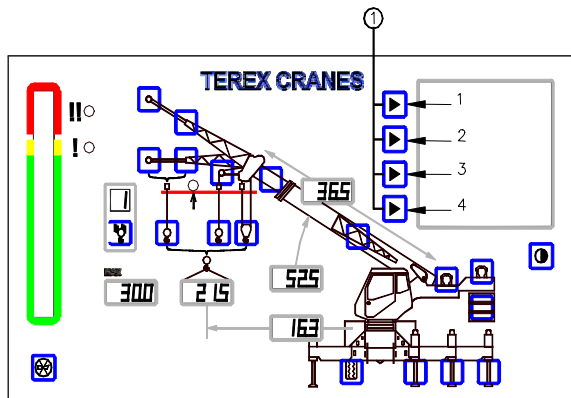

- Access the calibration routine by simultaneously pressing and holding **KEY (1)** and the **TEST** button (RED button on right side of display).
The display will request entry of the calibration Security Code.
- Enter the Security Code using the Calibration Arrow Keys 1-4, as shown above. These keys **MUST** be pressed in the following sequence:
Key (1), Key (3), Key (2), Key (4)
Note: If the wrong sequence is used or if the entry is not completed within 5 seconds, the calibration entry will be aborted and must be re-entered. After accessing the calibration routine, the system alarm will sound indicating that the system is in the calibration routine.
- Use the Up (2) or Down (3) arrow keys to scroll to command 03 Zero Sensor.
Press key (1)
- Use the Up (2) or Down (3) arrow keys to select TX 0 (pressure transducer 0 piston side). Press key (1).
- With the boom in the rest or the boom hoist cylinder fully retracted, relieve all pressure from both transducers. With no pressure, the upper display should indicate 0+/-20 bits.
- Next, use the Up (2) or Down (3) arrow keys to select TX1 (pressure transducer rod side). With no pressure in the cylinder, the upper display should read 0+/-20 bits.
- If the transducers were disconnected in step 5, tighten the fittings. With the boom fully retracted, boom up to a 60° angle.
- Access the Zero of TX 0, as described in step 4; the upper display should read 200+/-100 bits.
- Access the Zero of TX 1, as described in step 6; the upper display should read 5+/-25 bits.
- Boom down. As the boom is moving down, the displayed bits of TX 1 should increase.
- Place the retracted boom at a 60° angle. Access the Zero of TX 0, as described in step 4, and extend the boom. As the boom is extended, the displayed bits of TX 0 should increase. When the boom is fully extended, the display should read 400+/-100 bits for a three-section boom and 600+/-100 bits for a four-section boom.

The values listed are nominal values. The actual values will differ according to how the crane is equipped. A three-section boom will show a smaller value on TX 0 under the same conditions as a four-section boom. Additional equipment on the main boom, such as stowed fly, auxiliary head sheaves and hook blocks will give a higher value than the main boom alone.

If any value is out of range, contact your distributor or factory service department before replacing a pressure transducer.

Refer to page 20 of this manual for pressure transducer replacement.

- Exit the calibration routine by pressing the EXIT (4) key.

If the foregoing functional tests indicate faults in the pressure channels, proceed with Power Supply Tests and the test for resistance of the bridge of the pressure transducers.

PRESSURE TRANSDUCER-RESISTANCE MEASUREMENT

The pressure transducer is a balanced bridge composed of strain gauges bonded to a flexible diaphragm. The following resistance tests can be carried out to establish the viability of the pressure transducer.

Piston Pressure Transducer

NOTE: Place the boom in rest (truck drive) or in its lowest position (RT's) and relieve all pressure to atmosphere on both transducers.

- With the power to the computer off, disconnect the piston pressure transducer from the terminal blocks +DR, -DR, TX0+ and TX0- within the computer.
- With the DVM set to the Ohms range, measure the resistance between red and blue wires.
The resistance should be $350\Omega \pm 10\Omega$
- With the DVM set to the Ohms range, measure the resistance between yellow and green wires.
The resistance should be $350\Omega \pm 10\Omega$
- With the DVM set to the Ohms range, measure the resistance between pins. Each of the open wires red, blue, green, yellow and the case of the transducer. *There should be no connection between the case and any of the pins.*

Rod Pressure Transducer

NOTE: Place the boom in rest (truck drive) or in its lowest position (RT's) and relieve all pressure on both transducers to atmosphere.

- With the power to the computer off, disconnect the piston pressure transducer from the terminal block +DR, -DR, TX0+ and TX0- within the computer.
- With the DVM set to the Ohms range, measure the resistance between the yellow and green wires.
The resistance should be $350\Omega \pm 10\Omega$
- With the DVM set to the Ohms range, measure the resistance between pins, each of the open wires (red, blue, green, yellow) and the case of the transducer. *There should be no connection between the case and any of the pins.*

PRESSURE TRANSDUCER

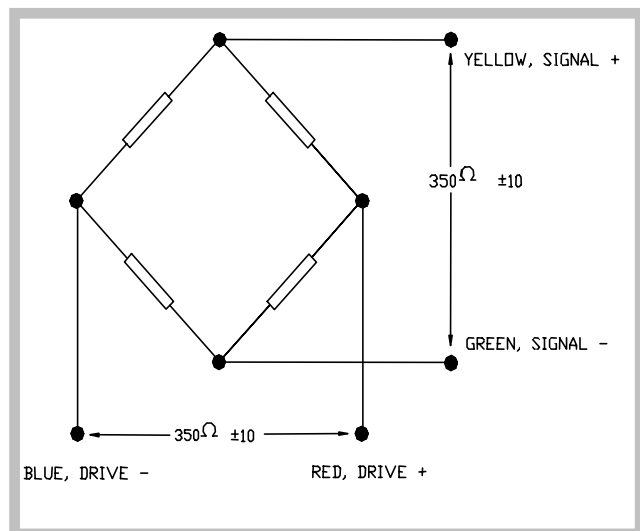
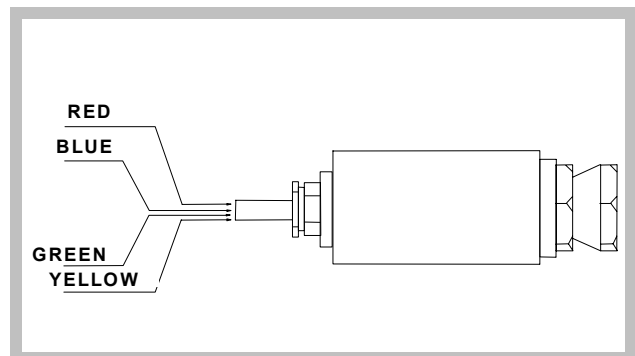

PRESSURE CHANNEL FAULT GUIDE

ANALOG DRIVE VOLTAGE

Analog sensor voltages are measured at the analog input group terminals.

The drive voltage for all analog sensors is measured between any +DR and -DR in the analog input group and is 5.25 volts DC +/- 0.1

To measure this voltage, use a digital voltmeter set to the DC voltage range.

1. Connect the black (negative) lead of the DVM to any DR- terminal in the analog input group.
2. Connect the red (positive) lead of the DVM to any DR+ terminal in the analog input group.
3. Measure the drive voltage.

volts DC +/- 0.1

4. If the voltage is out of range, disconnect all of the analog sensors by disconnecting the sensor connectors from the computer to determine if any sensor or its cabling is causing the drive voltage to be incorrect.
5. If the drive voltage is correct with all of the sensors disconnected, connect each sensor in turn to determine which sensor is causing the drive voltage to be incorrect.
6. If any sensor is causing the drive voltage to be incorrect, carry out the troubleshooting procedure for that sensor.

If the drive voltage is incorrect with all sensors disconnected, it may be necessary to replace the computer.

Before replacing the computer, carry out the Power Supply Tests detailed on Page 9 of this manual.

NOTE: FOR TECHNICIANS FAMILIAR WITH MG3:

UNLIKE THE MG3A SERIES, THE MG4 SERIES DOES NOT HAVE A DUAL CHANNEL PRE-AMPLIFIER. ANALOG VOLTAGES RELATIVE TO PRESSURE CANNOT BE MEASURED IN THE COMPUTER.

AIN0 AND AIN1 HAVE DIFFERENT FUNCTIONS IN THE MG4 SYSTEM AND ARE NOT TO BE USED TO MONITOR PRESSURE VOLTAGES.

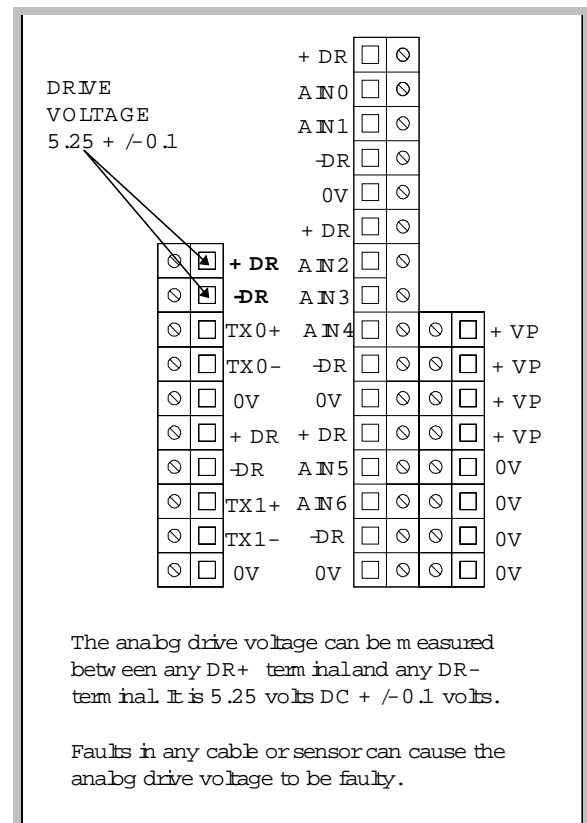

BOOM EXTENSION SENSOR AIN2

To check the Boom Extension Sensor Voltage, follow the procedure below.

1. Fully retract the boom.
2. Access the Computer and Termination Boards.

NOTE: Measure the analog sensor drive voltage. (Refer to page 9 of this manual).
3. With a digital voltmeter set to read DC voltage, place the negative lead on any 0 Volt terminal of the Analog Input Group.
4. Place the positive lead of the meter on the AIN2 terminal of the Analog Input Group. The voltage should be greater than 0.25 volts.
5. Extend the boom as far as is safe to do so. The boom need not be horizontal for this test.
6. The voltage should be less than 5 volts. (Usually around 2.5 volts depending on the boom length).
7. During **extension**, the voltage should **increase** linearly; during **retraction** the voltage should **decrease** linearly.
8. If the voltage is out of the range listed above, remove the four screws that secure the cover on the extension reel, which is located on the left side of the main boom section; remove the cover.
9. Under the cover on the right side of the extension reel is a terminal strip. This terminal strip has six wires connected to the bottom screws.
10. With a digital voltmeter set to read DC Voltage, place the negative lead on the terminal with the attached white wire (- Drive) and the positive lead on the terminal with the attached red wire (+Drive).
11. The voltage should be 5.25+/-0.1 volts. If this voltage is out of range, and if the Analog Drive Voltage measured in the computer was OK, it is possible that the cable is open or grounded between the computer and the

extension reel. Check all connections and plugs that may be between these two components. Repair or replace as required. Refer to the MicroGuard RCI 500 wiring details in the Installation Manual for the model of the crane being tested.

Continued on the next page.

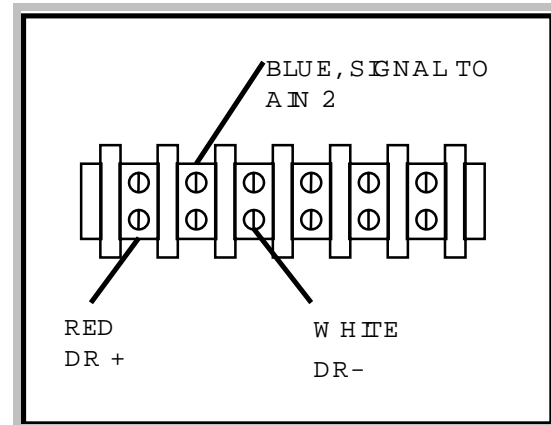

BOOM EXTENSION SENSOR AIN2 cont.

12 With the negative lead of the voltmeter connected to the white drive (DR-) and the positive lead of the voltmeter connected to the blue AIN2 extension signal, the voltage should be the same as the voltage measured at AIN2 of the analog input group in the computer. If this voltage is not the same, it is possible that the cable between the reel and the computer is faulty.

NOTE: The blue and white wires at the reel are **REVERSE** at the connector of the reel. Therefore, the white -DR at the reel is blue (-DR) in the computer. The blue signal (Extension AIN2) at the reel is white (AIN2) in the computer.

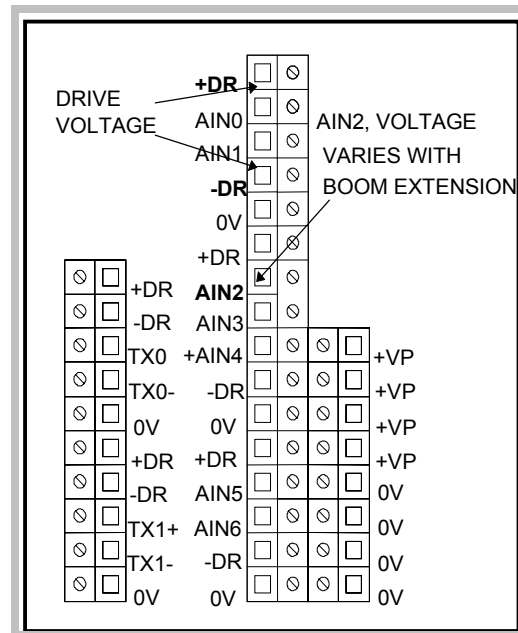

BOOM ANGLE SENSOR AIN 3

1. Place the main boom at a 0° angle. Verify that it is at a 0° angle with an inclinometer.
2. Access the Termination Board. Check the Analog Drive Voltage. (Refer to page 9 of this manual.)
3. With a digital voltmeter set for DC volts, connect the negative lead of the meter to any 0 (zero) volt terminal of the Analog Input Group.
4. Connect the positive lead to the AIN 3 terminal of the Analog Input Group.
5. With the boom horizontal, the voltage should be 0.4 +/- 0.1 volts.
6. Raise the main boom to a 60° angle. Verify that the main boom is at a 60° angle with an inclinometer.
7. With the boom at a 60° angle, the voltage should be 3.02 +/- 0.1 volts.
8. If this is out of range, remove the cover from the extension reel located on the left side of the main boom.
9. Under the cover on the right side of the extension reel is a terminal strip. This terminal strip has six wires connected to the bottom screws.
10. With a digital voltmeter set to read DC voltage, place the negative lead on the terminal with the white wire (-Drive) and the positive lead on the terminal with the red wire (+Drive).
11. The voltage should be 5.25 +/- 0.1 volts.

NOTE: If this voltage is out of range and the Analog Drive Voltage checked in step 2 is OK, it is possible that the extension reel cable is open or grounded between the computer and the extension reel. Check all connections and plugs between these two components. Repair or replace, as required. Refer to the MicroGuard RCI 500 wiring details in the Installation Manual for the model of crane being tested.

12. If the negative lead of the voltmeter is connected to the white drive (negative) and the positive lead of the voltmeter is connected to green (angle signal), the voltage should be the same as the voltage measured at AIN3 of the analog input group in the computer. If this voltage is not the same, it is possible that the cable between the extension reel and the computer is faulty or the boom angle sensor is faulty.
13. If the above voltage checks are within range and no grounds or opens are found in the wires, replace the Boom Angle Sensor, as described on pages 20-21 of this manual.

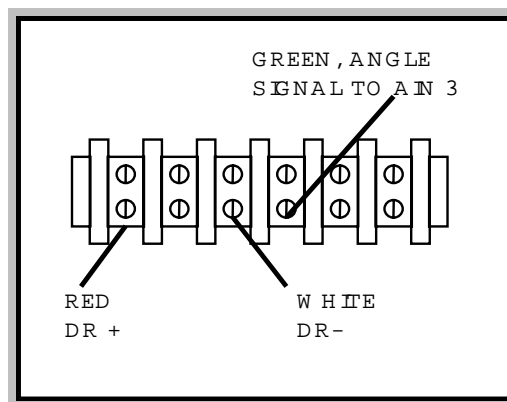
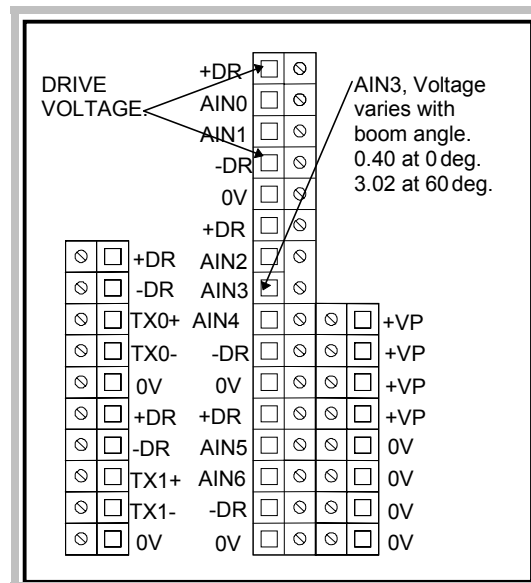

SWING POTENTIOMETER

AIN 5 AND AIN6

The position of the upper structure in relation to the carrier must be determined. This is accomplished by means of a swing potentiometer mounted in the collector ring. If the system does not have input from the swing potentiometer, it will not be able to find a duty.

To check the Swing Potentiometer, follow the procedure below:

1. Access the Termination Board.
Check the Analog Drive Voltage. (Refer to page 9 of this manual).
2. With a digital voltmeter set for DC volts, check the voltage at the connections to the potentiometer located on the Anti Two-Block board. Connection 1 has a red wire attached to it and connection 3 has a black wire attached to it.
3. Connect the black lead of the DVM to connection 3 (black wire) and the red lead of the DVM to connection 1 (red wire). The voltage should be 4.125 +/- 0.1 volts. If this voltage is out of range, the Termination Board may need to be replaced.
4. With the black lead on any 0 Volt terminal, check the voltage at the AIN 5 terminal and AIN 6 terminal. The voltage should be 4.50 +/- 0.1 maximum and 0.365 +/- 0.1 minimum. Both of these voltages should rise and fall linearly within this range as the upper is rotated left or right. If the Drive Voltage and the Voltage at the connection to the potentiometer were correct and the voltages on AIN 5 and AIN 6 are out of range, the swing potentiometer will need to be replaced.

Contact your distributor or your Factory Service Department for procedures on replacing the swing potentiometer.

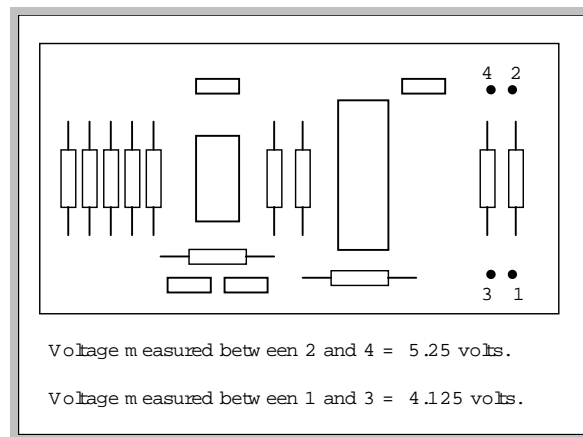
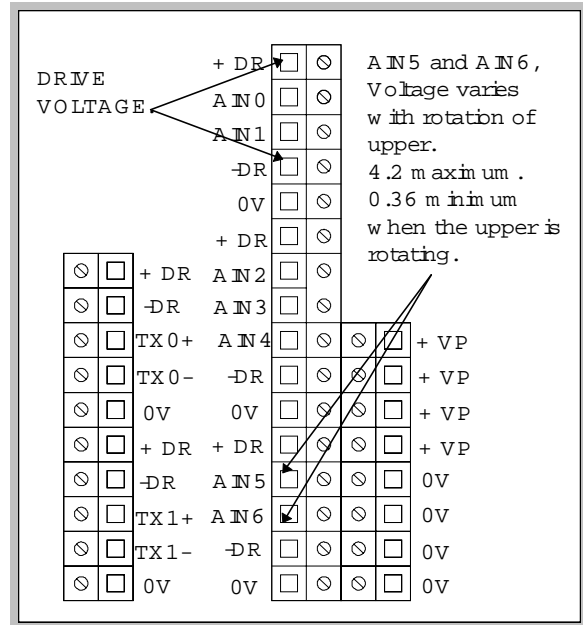

NO DUTY FOUND

The System requires the same information that the operator needs in order to read a load chart. If for any reason this information is not available, the fault “ No Duty Found “ will appear. This fault could occur if either the Boom Angle Sensor or the Extension Sensor inputs are faulty. The System uses these inputs to determine the duty selection. The System also uses information from the swing potentiometer to permit duty selection. Upon correction of the Sensor fault, the System will again be able to find a duty.

OTHER SYSTEM FAULTS**EXECUTIVE ROM**

The Executive ROM fault code indicates failure of IC2 on the main Processor Board. This chip can be replaced without the need for re-calibration. The chip is labeled M454400X.

PERSONALITY ROM

The Personality ROM fault code will be present until the system is fully calibrated. At the completion of calibration, a code is automatically inserted into the memory, which enables the system to carry out the self-test. If the fault code occurs in normal service, it could indicate either a failure of IC7 or the loss of data in the device. It will be necessary to obtain a copy of the Personality ROM that was made at the completion of the initial calibration or carry out a complete recalibration of the system. Contact your Distributor or Factory Service Department for details.

SCRATCHPAD RAM

The Scratchpad Ram fault code indicates the failure of IC6 on the Processor Board. This item is not user serviceable and requires the replacement of the Processor Board.

DUTY ROM

This fault is associated with the failure of the Duty Chip IC3 on the Processor Board. It can be replaced without the need for recalibration. It contains the load chart data for the crane on which it is fitted and must be identical to the load chart on the crane.

CURRENT DUTY BAD

This fault indicates failure of the Duty Chip IC3 on the Processor Board. The Duty chip can be replaced without the need to re-calibrate. This chip contains the load chart data for the crane on which it is fitted and must be identical to the load chart on the crane.

CONFIGURATION UNCALIBRATED

When a crane is initially calibrated, its duty chip may contain more configurations than are to be sold with that particular crane. Fly or jib options that are not supplied with the crane will not show up in the Crane Set Up menu. Refer to the Calibration Procedure, Command 13 to hide or show attachments.

DIGITAL I/O & ANALOG I/O

Digital and Analog I/O faults are not user serviceable. When this fault code is detected, it will be necessary to replace the Processor Board.

DISPLAY UNIT

This unit is not user-serviceable. When this fault code is detected, it will be necessary to replace the Display Unit. This can be done by removing the four screws securing the display to the dashboard and unscrewing the cable from the back of the display. Connect the display cable to the new display, install it into the dashboard, and secure with the four mounting screws.

ANTI TWO BLOCK SYSTEM**SYSTEM WILL NOT SHOW TWO-BLOCK WHEN THE CRANE IS TWO-BLOCKED**

1. Access the Termination Board. (Refer to page 8 of this manual.)
2. Remove and separate the violet and brown wires connected to the ATB IN terminal of the digital input group.

The system should now show an Anti Two-Block warning.

- If the Anti Two-Block warning does not occur with the wires removed from the terminal strip, the problem is in the Termination Board.
 - If the Anti Two-Block warning occurs with the wires removed from the terminal strip, the problem is outside of the computer and is in the A2B switches and/or cables. Reconnect the wires to the ATBIN terminal.
3. Remove the four cover screws from the extension reel located on the left side of the main boom and remove the cover.
 4. Remove the brown wire from the terminal strip. **The system should now show an Anti Two-Block warning.**

If it does not, the brown wire or its connections between the Terminal Board and the extension reel are shorted to ground.

If the system shows an Anti Two-Block warning, there is a short circuit to ground in the wiring or connections between the extension reel and the Switch at the boom head.

5. Check all wires and connections between the computer and the reel and switches and repair or replace, as required.

SYSTEM SHOWS TWO-BLOCK WHEN CRANE IS NOT TWO-BLOCKED

1. Check that the selection switch of the Two-Block switch located at the main boom head is correctly set.

2. Ensure that the Anti Two-Block weight is attached to the boom head switch.
3. Access the Termination Board. (Refer to page 8 of this manual.)
4. Connect a jumper wire from the 0 volt terminal to the ATBIN terminal leaving the brown and violet wires in place in the ATBIN terminal. The Anti Two-Block warning should no longer be displayed.
 - If the Anti Two-Block warning remains, the problem is in the Termination Board assembly.
 - If the Anti Two-Block warning goes away with 0 volt connected to ATBIN, the problem is in the external wiring or switches.
5. Remove the jumper wire connected in Step 4. Remove the four screws from the extension reel located on the left side of the main boom.
6. Connect a jumper wire between the black wire and the brown wire on the terminal strip.

The Anti Two-Block warning should no longer be displayed.

- If it remains, the brown wire is open between the Termination Board and the Extension Reel.

If the warning is no longer displayed, the problem is somewhere between the extension reel and the boom head switch. Check all wires and connections between these components and repair or replace, as required.

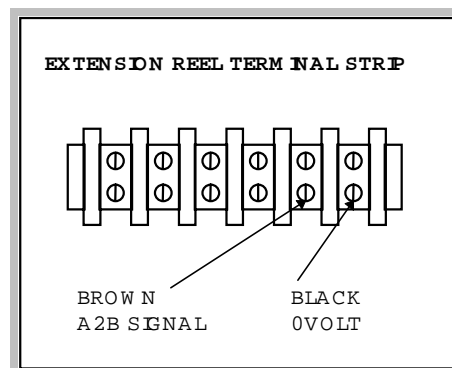

ANTI TWO-BLOCK LOGIC LEVELS

The signal from the Anti Two-Block (ATB) switches at the boom and fly tips is a switched ground. The ground signal is powered in the computer at the 0 volt terminal of the digital input group.

When there is no ATB alarm, the switches at the boom head are *closed* allowing the ground to be returned to the computer at the ATBIN terminal.

When there is a two-block condition, the appropriate ATB switch will go to the open position, thereby removing the ground from ATBIN and causing ATB Alarm and Function Disconnect.

The ATB alarm and Function Disconnects are controlled separately by the ATB board in the computer.

The ATB board, located in the computer box:

- Operates the function disconnects by controlling the coil of RL2, ATB relay, at D OUT 1.
- Operates the audible alarm and on screen message by controlling the logic level at DIN13.

The logic levels are as follows:

	NO ALARM	ATB ALARM
ATB SWITCH	CLOSED	OPEN
ATB IN	LOW 0.2 VOLT	HIGH 5 VOLT
D OUT 1	LOW 0.2 VOLT	HIGH 5 VOLT
D IN 13	HIGH 12 VOLT	LOW 0.2 VOLT

The voltage levels are approximations and small variations are to be expected.

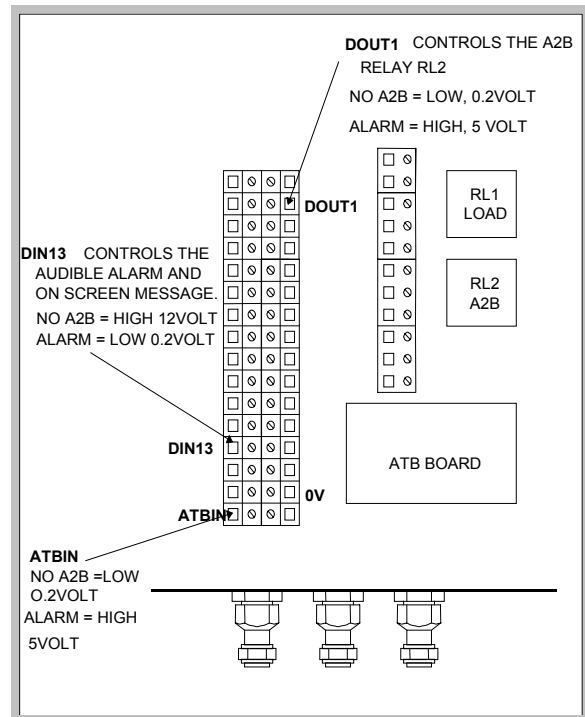

PRESSURE TRANSDUCER REPLACEMENT

1. It is recommended that the replacement transducer is closely matched to the sensitivity of the old transducer. The sensitivity value is recorded on the serial number plate.
2. Remove the connector connecting the transducer to be replaced from the computer box.
3. With the boom cylinder completely retracted, in the rest, or with the boom safely supported, remove the transducer to be replaced.
4. Install the new transducer on the boom hoist cylinder.
5. Run the cable to the computer box and connect it to the appropriate computer box connector.
6. Pick a known weight to verify the accuracy of the system. If the load reading is not within tolerance after the replacement of a pressure transducer, first carry out Command 03 (zero sensors) for the appropriate sensor only. Check accuracy again. If the system is still out of tolerance, carry out Command 6 (Pressure), and Command 7 (Radius Moment). This should correct any inaccuracy in the RCI 500 Calibration procedure.

EXTENSION REEL REPLACEMENT

To replace the Extension Reel Assembly, use the following procedure:

1. Fully retract the main boom.
2. Disconnect the connector to the Anti Two-Block switch and remove the cable from the main boom head anchor. Allow the cable to retract onto the reel. Take care not to let the cable retract too rapidly.
3. Remove the Extension Reel Cable connector.

4. Remove the four mounting bolts (5) securing the Extension Reel to the boom. Remove the reel.
5. Mount the new reel to the boom, secure with the mounting bolts, and connect the Extension Reel Cable Connector.
6. Remove the shipping cable clamp from the new cable and allow it to slowly rewind onto the reel until there is no pre-tension. Continue to rewind the reel in the same direction until the distance between the boom head and the connector is approximately 12 ft. At this point there will be no pre-tension.
7. Pull the cable out, passing it through the cable guides until the end of the cable is 3 ft. beyond the boom head.
8. Wrap the cable around the boom head anchor a minimum of five times and secure with a wire tie or shipping cable clamp.
9. Connect the cable to the connector coming from the Anti Two-Block switch.
10. Manually turn the large gear connected to the potentiometer fully counterclockwise.
11. Observe the length display and turn the large gear at least 3 clicks clockwise until the length display reads the retracted boom length.
12. Replace the Extension Reel Cover, securing it with the four screws.
13. Extend and retract the main boom and ensure that the boom length reading on the display is correct.

BOOM ANGLE SENSOR REPLACEMENT

To replace the Boom Angle Sensor that is fitted inside the extension reel, use the following procedure:

1. With the power off, remove the 4 bolts holding the cover of the extension reel and remove the cover.
2. Disconnect the 3 wires connecting the angle sensor to the terminal strip. Remove the two

bolts securing the sensor to the extension reel and remove the old angle sensor.

3. Install the new sensor in the extension reel in the original location, secure it with the mounting bolts, and connect the cable.
4. Raise the boom to a 60° angle and verify the angle with an inclinometer. While viewing the display, adjust the sensor until the display reads 60°. Tighten the mounting bolts.
5. Place the boom in a horizontal position. With an inclinometer, verify that the boom angle is at zero degrees.
6. Verify that the displayed boom angle reads (zero) 0° +/- 0.5°.

EXECUTIVE ROM CHIP REPLACEMENT

The Executive ROM Chip contains the main program data that the computer uses to function and must be specific to the System.

1. Access the Processor Board.
Refer to pages 8 and 23 of this manual.
2. With the power off, remove IC2, the Executive ROM Chip, from its socket.
Refer to General Chip Removal and Installation in this manual.
3. Install the new Executive ROM Chip into the socket. Make certain the notch in the chip is lined up with the notch in the socket and all pins are properly inserted.

PERSONALITY ROM CHIP REPLACEMENT

The Personality ROM Chip must be the proper chip for the particular crane serial number. This chip contains calibration data that is unique to each crane.

1. Access the Processor Board. (Refer to pages 8 and 23 of this manual.)
2. With the power off, remove IC7, the Personality ROM Chip, from its socket. (Refer to General Chip Removal and Installation in this manual).

3. Install the new Personality ROM Chip into the socket. Make certain the notch in the chip is lined up with the notch in the socket and all pins are properly inserted.

DUTY ROM CHIP REPLACEMENT

The Duty ROM Chip must be specific to the load chart used in the crane. This chip contains a copy of the load chart and must match the load chart in the crane.

1. Access the Processor Board. (Refer to page 8 of this manual).
2. With the power off, remove IC3, the Duty ROM Chip from its socket. (Refer to General Chip Removal and Installation in this manual).
3. Install the new Duty ROM Chip in the socket. Ensure that the notch in the chip is lined up with the notch in the socket and all pins are properly inserted.

NOTE: *Replacement of the Executive or Duty ROM Chip does NOT necessitate the re-calibration of the system.*

NOTE: Replacement of the Personality ROM Chip does NOT necessitate re-calibration of the system if the new Personality ROM Chip is an exact duplicate of the original. If a copy of the Personality Chip *is not available*, the System will need to be completely re-calibrated.

PROCESSOR BOARD REPLACEMENT

1. With the power off, access the Processor Board. (Refer to pages 8 and 23 of this manual).
2. Locate the two ribbon cables connecting the Processor Board to the Termination Board.
3. The ribbon cables are held in place by two locking tabs on each cable end. These locking tabs must be pushed away from the cable to disconnect the cable. As the locking tabs are pushed, the connector will come loose from the Processor Board.
4. Loosen the two screws holding the computer backing plate to the box.

5. Remove the Processor Board Assembly.

There are three computer chips on the Processor Board that must be the correct type.

These three chips are:

IC2 Executive ROM

IC3 Duty ROM

IC7 Personality ROM

The Executive ROM must be specific to the System.

The Duty ROM contains a copy of the load chart and must correspond to the Load Chart Number of the particular serial number of the crane.

The Personality ROM contains data that is unique to the particular serial number of the crane.

6. Install the:
 - Executive ROM Chip
 - Duty ROM Chip
 - Personality ROM Chip
7. Place the Computer Assembly into the computer box and tighten the two mounting screws; be careful to allow access to the ribbon cables.
8. Reconnect the two ribbon cables. Fully engage the connector and locking tabs.
9. Replace the Computer Box cover and secure with the four screws.

COMPUTER BOX REPLACEMENT

TERMINAL BOARD AND BOX ONLY

USE THE PROCESSOR BOARD FROM THE ORIGINAL BOX.

1. Remove the Processor Board.
2. Label each cable. Refer to page 24. Then label each wire with its terminal location. Remove cable from gland entry. Repeat with each cable.
3. Remove the four screws securing the Computer Box.

4. Remove the Computer Box.
5. Install the new computer and secure with the four mounting screws.
6. Reconnect all cables in reverse of removal.

CHIP REMOVAL AND INSTALLATION

When removing and installing chips, switch off the power. **Do not touch the chip pins** if you are not properly grounded. Static electricity can damage chips.

1. Ensure that the power is off.
2. Remove the chip to be replaced with a chip removal tool.
NOTE: Chip removal and installation tools are available from any electronics store.
3. Insert the new chip into the installation tool per the instructions on the package.
4. Insert the new chip into the socket, ensuring that the notch in the chip (1) lines up with the notch in the socket (2).
5. Double check that all pins are properly inserted into the chip socket. These pins are very easily bent. Failure to have all pins inserted can cause damage to the System and the chip.

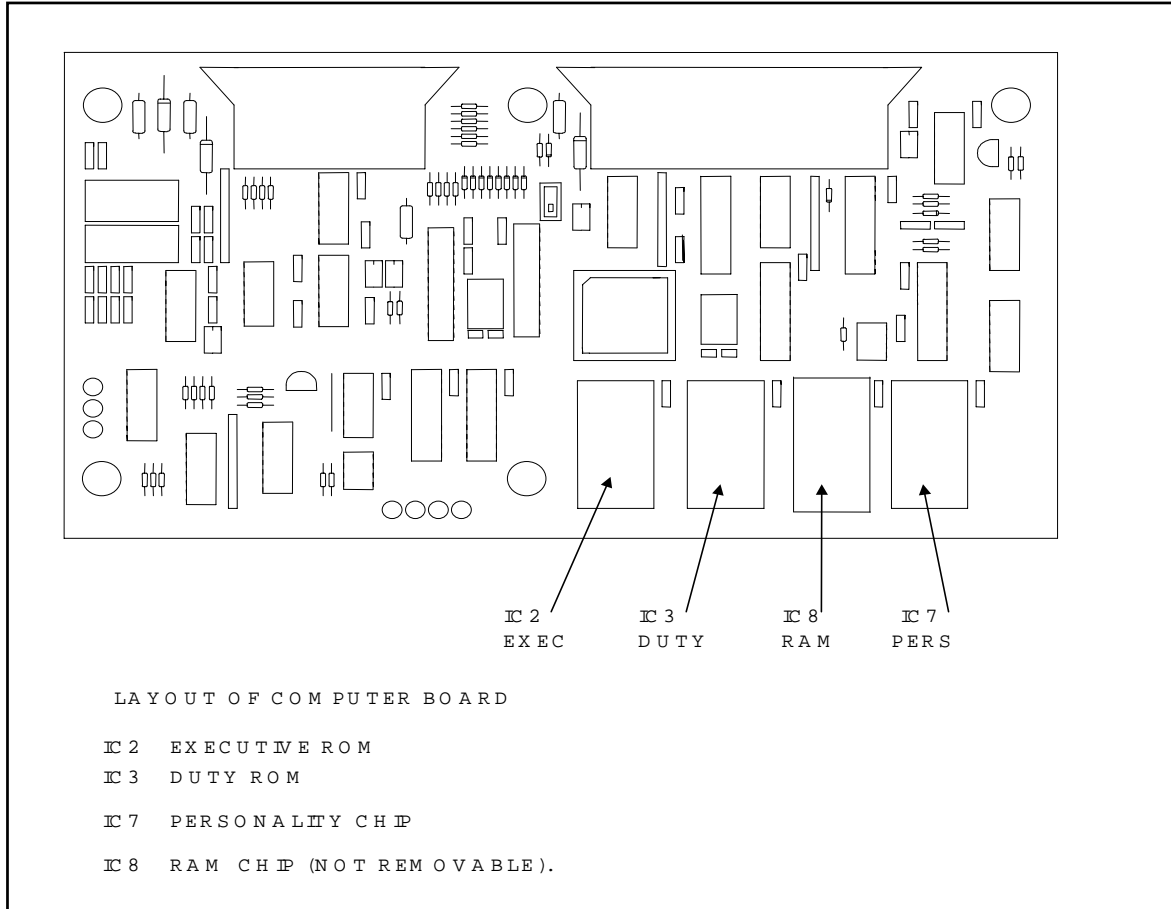

PROCESSOR BOARD LAYOUT

TERMINATION BOARD

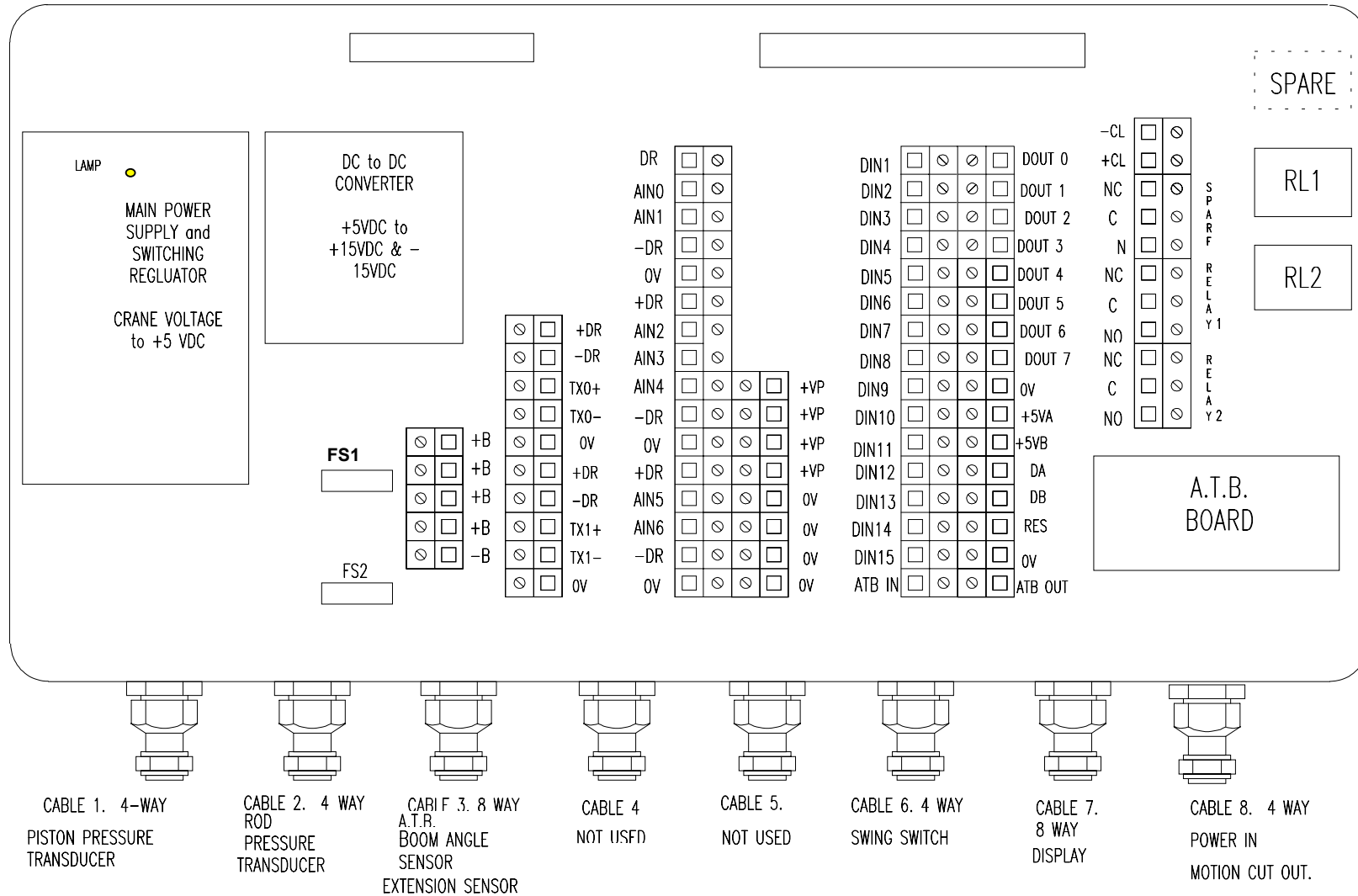

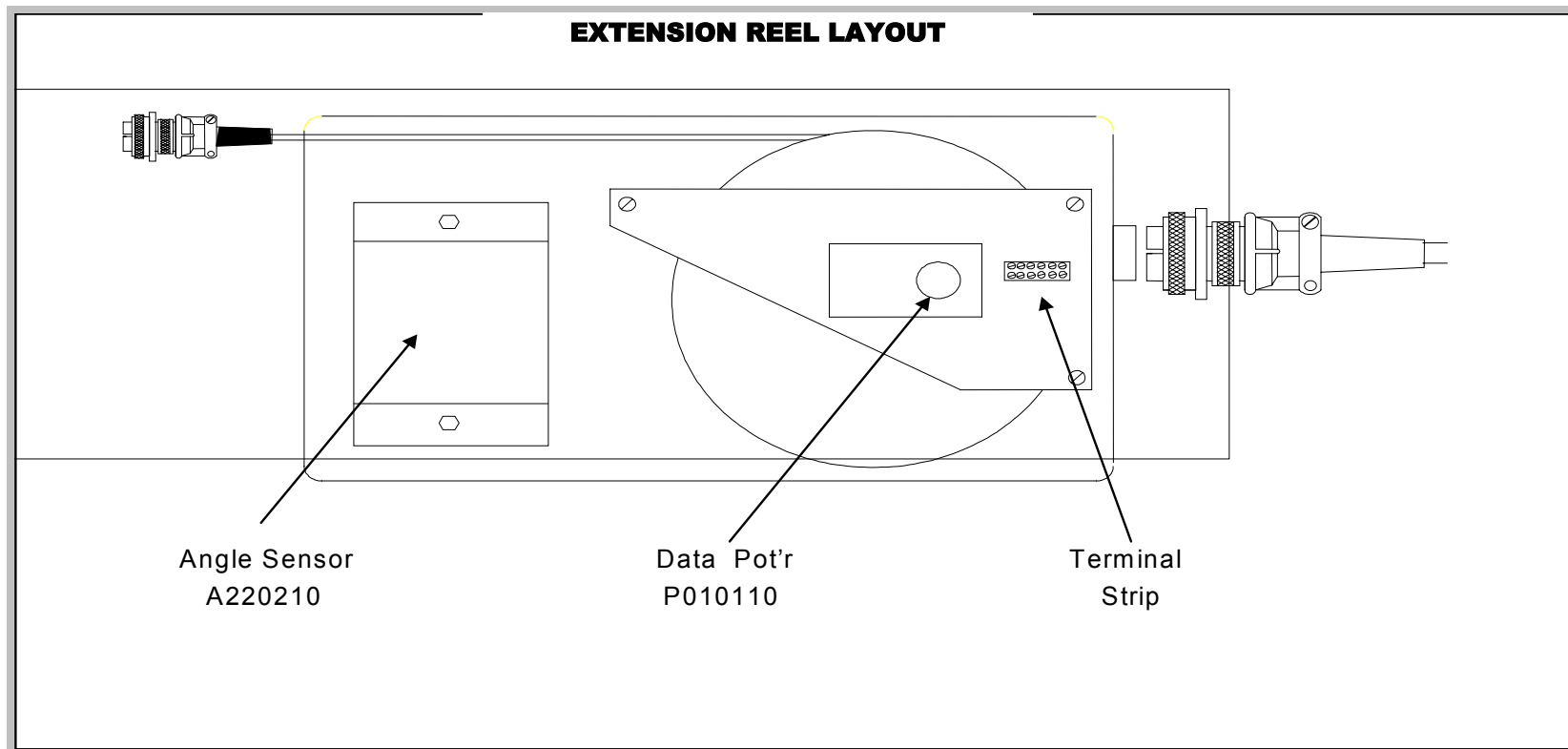

GLOSSARY OF TERMS

ABORT	TO STOP DATA ENTRY INTO THE SYSTEM BEFORE THE ENTRY PROCESS IS FINALIZED.
ALARM	A VISUAL OR AUDIBLE WARNING SIGNAL.
AMPLIFIER	INCREASES MAGNITUDE –EXAMPLE: A PRESSURE TRANSDUCER IN THE MILLIVOLT RANGE IS INCREASED OR AMPLIFIED UP TO TEN VOLTS.
AMPLIFIER GAIN	THE FACTOR USED TO EXPRESS THE LEVEL OF AMPLIFICATION.
ANALOG	A MECHANISM IN WHICH DATA IS REPRESENTED BY CONTINUOUSLY VARIABLE PHYSICAL QUANTITIES.
ANGLE SENSOR	A DEVICE THAT MEASURES THE ANGLE OF THE BOOM RELATIVE TO THE HORIZON.
ANNULAR	RELATING TO, OR FORMING A RING, E.G., THE PRESSURE AROUND THE ROD OF A BOOM HOIST CYLINDER
ANNULAR GAIN	THE FACTOR USED TO MODIFY THE PRESSURE SIGNAL FROM THE ROD SIDE OF THE BOOM HOIST CYLINDER BASED ON THE DIFFERENCE IN AREAS OF THE ROD AND THE BORE.
BACKUP	IN THIS CASE, A COPY OF DATA SAVED IN A SEPARATE COMPUTER CHIP.
BOOM DEFLECTION	A CHANGE IN RADIUS DUE TO THE BENDING OF THE BOOM CAUSED BY THE WEIGHT OF LOAD.
BOOM MOMENT	THE TURNING MOMENT AROUND THE BOOM PIVOT CAUSED BY THE MOMENT OF THE UNLADEN BOOM.
BORE	THE PISTON SIDE OF A BOOM HOIST CYLINDER.
CALIBRATION	THE ADJUSTMENT OF THE GRADUATION OF SENSORS.
CAPACITY CHART	A TABLE SUPPLIED BY THE CRANE MANUFACTURER SHOWING THE SPECIFICATIONS AND RATINGS FOR EACH INDIVIDUAL CRANE.
CENTER OF GRAVITY	THE POINT AT WHICH THE ENTIRE WEIGHT OF A BODY MAY BE CONSIDERED AS CONCENTRATED SO THAT IF SUPPORTED AT THIS POINT THE BODY WOULD REMAIN IN EQUILIBRIUM IN ANY POSITION.
CONFIGURATION	THE POSITION OF THE CRANE, SUPPORTING APPENDAGES, AND ALL LIFTING ELEMENTS.
DATA	FACTUAL INFORMATION USED AS A BASIS FOR CALCULATION.
DEDUCT	A REDUCTION IN RATED CAPACITY FOR AN UNUSED STOWED OR ERECTED ATTACHMENT.
DEFLECTION	THE BENDING OF A BOOM OR THE STRETCHING OF PENDANT LINES WITHIN THE ELASTIC LIMITS OF THE BOOM OR PENDANTS.

DIGITAL	OPERATING WITH NUMBERS SHOWN AS DIGITS.
DIGITAL INPUTS	COMPUTER INPUTS USUALLY CONTROLLED BY EXTERNAL ON/OFF SWITCHES.
DIRECTION	THE COURSE ON WHICH THE UPPER SECTION (SUPERSTRUCTURE) OF A CRANE ROTATES.
DUTY	THE WORKING CONFIGURATION OF A CRANE THAT CAN USUALLY BE FOUND IN A SINGLE COLUMN OF A CAPACITY CHART.
EEPROM	ELECTRICALLY ERASABLE AND PROGRAMMABLE "READ ONLY" MEMORY. (ROM)
ELASTIC	CAPABLE OF RECOVERING SIZE OR SHAPE AFTER EXPANSION.
ERECTED ATTACHMENT	AN ATTACHMENT ON THE MAIN BOOM IN WORKING (NOT STOWED) POSITION.
EXTENSION SENSOR	A DEVICE THAT MEASURES THE EXTENSION OF THE TELESCOPING SECTIONS OF A BOOM.
FLY/JIB	AN ATTACHMENT CONNECTED BY ONE EDGE TO A CRANE BOOM, E.G., A LATTICE FLY OR JIB.
FORCE	ENERGY REQUIRED, IN THIS CASE, TO SUPPORT THE WEIGHT OF AN OBJECT.
GEOMETRY	MATHEMATICS ADDRESSED TO THE MEASUREMENT AND RELATIONSHIP OF POINTS, LINES, ANGLES, SURFACES, AND SOLIDS.
GRADUATED	MARKED WITH DEGREES OF MEASUREMENT.
HEIGHT	THE VERTICAL DISTANCE FROM THE GROUND TO THE TIP OF THE BOOM OR ATTACHMENT.
HITE	AN ABBREVIATION OF HEIGHT. THE HEIGHT OF THE BOOM PIVOT ABOVE GROUND LEVEL.
HORIZONTAL	PARALLEL TO THE HORIZON.
HYDRAULIC CRANES	USING THE PRESSURE OF OIL FOR OPERATION.
INCREMENT	THE ACTION OF INCREASING A NUMBER OR VALUE.
INITIALIZES	PREPARES PERSONALITY A COMPUTER MEMORY CHIP FOR NEW CALIBRATIONS. ERASES ALL EXISTING DATA DURING THIS PROCESS.

INTEGRATED CIRCUITS	A TINY COMPLEX OF ELECTRONIC COMPONENTS AND CONNECTIONS COLLECTED ON A SMALL SLICE OF MATERIAL (SUCH AS SILICON).
MEASURE HEIGHT	TO DETERMINE THE VERTICAL DISTANCE FROM BELOW THE BOOM PIVOT TO THE GROUND. RADIUS MEASUREMENTS ARE MADE FROM THESE POINTS WHEN CALIBRATING.
MEASURE HEIGHT	TO DETERMINE THE VERTICAL DISTANCE FROM BELOW THE BOOM PIVOT TO THE GROUND. RADIUS MEASUREMENTS ARE MADE FROM THESE POINTS WHEN CALIBRATING.
MICROPROCESSOR	A COMPUTER PROCESSOR CONTAINED ON AN INTEGRATED CHIP.
MILLIVOLT	ONE THOUSANDTH OF A VOLT.
MOMENT	THE PRODUCT OF FORCE AND DISTANCE IN RELATION TO A PARTICULAR AXIS OR POINT.
OUT OF DUTY	A POINT THAT IS EITHER LONGER THAN THE LONGEST PERMITTED RADIUS OR LOWER THAN THE LOWEST PERMITTED ANGLE ON A CAPACITY CHART.
OUTRIGGER	A MECHANICAL DEVICE THAT PROJECTS FROM THE MAIN STRUCTURE OF THE CRANE TO PROVIDE ADDITIONAL STABILITY OR SUPPORT.
PERSONALITY	COMPUTER CHIP STORING ACTIVE CALIBRATION DATA.
PRESSURE	HYDRAULIC PRESSURE IN THE BOOM HOIST CYLINDER.
RADIUS	THE HORIZONTAL DISTANCE FROM THE CENTERLINE OF ROTATION TO THE CENTER OF THE HOOK.
RATED CAPACITY	THE LIFTING CAPACITY OF A CRANE AS PROVIDED BY THE MANUFACTURER IN A CAPACITY CHART.
RATED CAPACITY	THE LOAD THAT A CRANE CAN SAFELY HANDLE BASED ON FACTORS SUCH AS STRENGTH, STABILITY, AND RATING.
RATING	A FACTOR DETERMINED BY LEGISLATION THAT LIMITS THE ACTION OF A CRANE IN A LIFTING OPERATION. USUALLY EXPRESSED AS A PERCENTAGE OF STRENGTH OR STABILITY.
RESTORE	TO MOVE CALIBRATION DATA FROM A BACK UP CHIP TO THE PERSONALITY "A" ACTIVE CHIP.
ROM	"READ ONLY" MEMORY. DATA CAN BE READ BUT NOT CHANGED AFTER PROGRAMMING.
ROPE LIMIT	THE MAXIMUM PERMITTED SINGLE LINE PULL DETERMINED BY THE CONSTRUCTION AND DIAMETER OF A WIRE ROPE.
SAVE	TO MOVE DATA FROM THE WORKING PERSONALITY TO A 'WRITE PROTECTED' AREA OF MEMORY.

SCALE	THE USE OF A FACTOR TO SET THE SCALING OF ANALOG SENSORS. SOMETHING GRADUATED WHEN USED IN MEASUREMENT.
SENSITIVITY	THE CAPACITY OF A SENSOR TO RESPOND TO PHYSICAL STIMULI.
SENSOR	A DEVICE THAT RESPONDS TO A PHYSICAL STIMULUS AND TRANSMITS A RESULTING IMPULSE.
SHEAVE	A GROOVED WHEEL OR PULLEY.
SLEW OFFSET	THE HORIZONTAL DISTANCE FROM THE BOOM PIVOT TO THE CENTER OF ROTATION.
SPAN	AN EXTENT OR SPREAD BETWEEN TWO LIMITS.
SPAN	THE CALIBRATION OF AN ANALOG SENSOR BETWEEN ZERO AND MAXIMUM SPAN.
STOWED ATTACHMENT	AN ATTACHMENT USUALLY STORED IN AN INACTIVE POSITION ON THE MAIN BOOM.
SUPERSTRUCTURE	THE STRUCTURAL PART OF A CRANE ABOVE THE CARRIER, USUALLY ROTATING.
SWING	THE ROTATION OF A CRANE UPPER AROUND ITS CENTER LINE.
SWL (%SWL)	PERCENTAGE OF 'SAFE WORKING LOAD.' THE PROPORTION OF THE CRANE CAPACITY THAT IS BEING UTILIZED AT ANY ONE TIME EXPRESSED AS A PERCENTAGE OF RATED CAPACITY.
TRANSDUCER	A DEVICE THAT IS ACTUATED BY ENERGY FROM ONE SYSTEM AND CONVERTS THIS TO ANOTHER FORM FOR USE BY A DIFFERENT SYSTEM (AS A LOUDSPEAKER THAT IS ACTUATED BY ELECTRICAL SIGNALS AND SUPPLIES ACOUSTIC POWER).
TX.0	THE PISTON SIDE PRESSURE TRANSDUCER.
TX.1	THE ROD SIDE PRESSURE TRANSDUCER.
UNLADEN	A BOOM THAT HAS NO ADDITIONAL STOWED OR ERECTED ATTACHMENTS AND IS NOT SUPPORTING A LOAD.
	UNIT OF ELECTRICAL POTENTIAL DIFFERENCE AND ELECTROMOTIVE FORCE.
WEIGHT	THE AMOUNT THAT A BODY WEIGHS OR THE POUNDAGE TO BE CARRIED BY A HORSE IN A HANDICAP RACE.

WRITE PROTECTED	AN AREA OF MEMORY IN A COMPUTER THAT CANNOT BE ACCESSED BY A MICROPROCESSOR FOR DATA ENTRY OR CHANGE.
ZERO	THE ZERO POINT ON A GRADUATED SCALE.



GREER COMPANY, 1918 EAST GLENWOOD PLACE, SANTA ANA, CA 92705
TEL: (714) 259-9702 FAX: (714) 259-7626 MicroGuard®

PN W450193 REV A 01/27/03
RCI-500 TROUBLESHOOTING MANUAL